

# CATALOGUE

SIGNALISATION



signa**zip** 

## INSTALLATION DE SIGNALISATION

Signazip se démarque par son service de location, d'installation et démantèlement de signalisation sur tout le territoire de l'Abitibi-Témiscamingue. Nous offrons une solution clé en main pour tous les besoins de signalisation de chantier : routier, minier, industriel ou forestier. C'est aussi la tranquillité d'esprit de s'en remettre à des experts de la signalisation qui travaillent avec fiabilité, professionnalisme, et qui sont membres de l'Association des Transports du Québec (STC-102).

Signazip offre aussi le service de réalisation de plan de signalisation, signé et scellé par un ingénieur.

# signa

## SERVICE DE SIGNALEURS

En plus du service d'escorte routière, nous vous offrons également plusieurs équipes de signaleurs certifiés, disponibles 24 heures par jour, 7 jours sur 7, et ce, partout en région. Nos signaleurs sont sécuritaires et font une gestion efficace de la sécurité routière.

Téléphone :  
819-727-9818  
Sans frais :  
1 866-666-9818

# zip



Leader en signalisation routière, Signazip est heureux de vous présenter son catalogue de signalisation.

Assurer la sécurité des usagers de la route, celles des travailleurs de chantiers routiers et industriels, tout en favorisant la mobilité et la fluidité de la circulation, voilà ce que nous avons pour but.

Située à Amos, notre usine moderne de plus de 5 000 pieds carrés nous permet de fabriquer des panneaux de signalisation à grand volume, et ce, en continuant de créer des emplois en région.

Signazip offre une gamme complète de produits de signalisation routière, minière, industrielle et forestière en plus de fabriquer des panneaux de prescription, travaux routiers, danger, indications et plusieurs types de balises.

Pour une soumission:  
[ziplignes@cableamos.com](mailto:ziplignes@cableamos.com)

## FABRICATION SUR MESURE

De la conception à la fabrication des produits, Signazip propose un savoir-faire global. Le panneau que vous recherchez ne se trouve pas dans notre catalogue? Contactez-nous dès aujourd'hui car nous fabriquons aussi des panneaux sur mesure qui sauront répondre exactement à vos besoins.

## **PLAQUES TOPONYMIQUES 6**

## **ACCESSOIRES DE SIGNALISATION 7**

Produits de fixation 8

Fixations 8

Poteaux et accessoires 8

Bases de signalisation en béton 10

## **PRODUITS DE SIGNALISATION 11**

Équipement de signalisation 12

Sécurité et travaux 12

Balises routières et cônes 13

## **< PANNEAUX D'ALUMINIUM > 14**

## **SIGNALISATION DE TRAVAUX ROUTIERS 15**

Montage sur véhicules d'accompagnement 22

## **SIGNALISATION DE PRESCRIPTION 23**

Panneaux spéciaux 35

## **< PANNEAUX DE CAMÉRA > 36**

## **SIGNALISATION DE DANGER 37**

## **SIGNALISATION D'INDICATION 47**

Pictogrammes 56

### **< LOCATION DE RADAR > 60**

## **SIGNALISATION DE VOIES CYCLABLES 61**

## **SIGNALISATION SPORTIVE 69**

Ski alpin 70

Ski de fond 73

## **SIGNALISATION DE MOTONEIGE 75**

## **SIGNALISATION INDUSTRIELLE 83**

Réglementation 84

Information - Urgence santé et générale 85

Information - Exploitation / Avertissement - Danger 86

Avertissement - Attention / Interdictions 87

### **< PANNEAUX DE PROTECTIONS OBLIGATOIRES > 88**

## **TRANSPORT 89**

Transport de marchandises dangereuses 90

Transport routier 91

# PLAQUES TOPONYMIQUES

Plaques d'identification des rues - Extrusions d'aluminium

RUE **PRINCIPALE**

**NR-1**

Lettrage blanc sur fond vert réfléchissant

6,25" x 24"

6,25" x 30"

6,25" x 36"

RUE **PRINCIPALE**

**NR-2**

Lettrage et bordure blanche sur fond vert réfléchissant

6,25" x 24"

6,25" x 30"

6,25" x 36"

# PLAQUES TOPONYMIQUES

*Personnalisées*

Plaques d'identification des rues - Extrusions d'aluminium

Impression numérique couleur sur pellicule réfléchissante

6,25" x 24" / 6,25" x 30" / 6,25" x 36"



Avenue des Huards



Chemin des Collines

Plaques d'identification des rues - Aluminium plat

Impression numérique couleur sur pellicule réfléchissante

Dimensions personnalisées



**CNC**

Nous offrons un service de découpe à la CNC qui nous permet de découper toutes sortes de formes personnalisées.

# ACCESSORIES

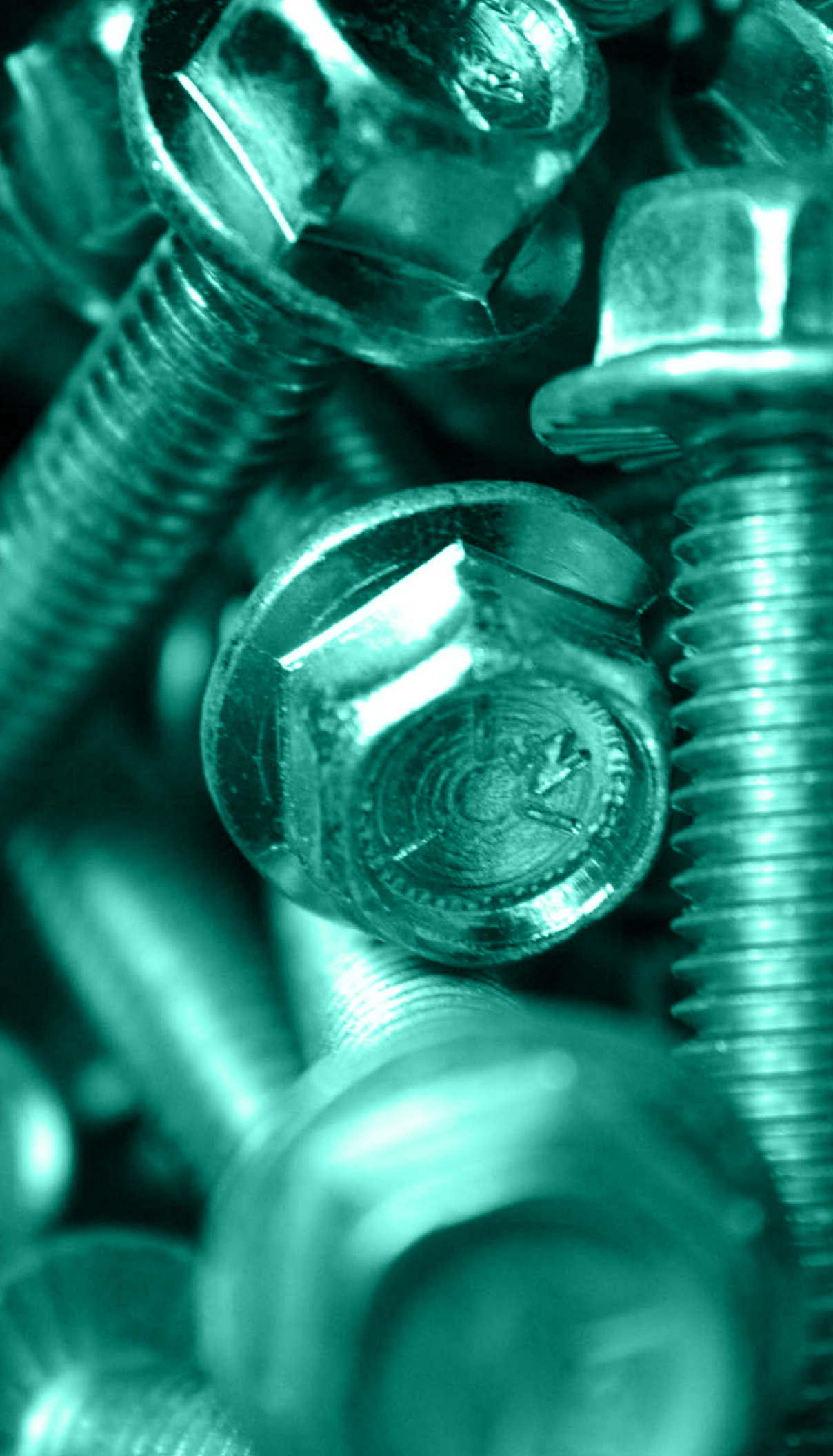

## PRODUITS DE FIXATION ET FIXATIONS

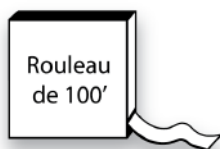

**C-001**  
Tendeur de courroie

**C-204**  
Courroie en acier inoxydable 1/2" x 100'

**C-254**  
Boucles 1/2" (100 par boîte)

**D-310**  
Attaches évasées 1/2" (50 par boîte)

**C-206**  
Courroie en acier inoxydable 3/4" x 100'

**C-256**  
Boucles 1/2" (100 par boîte)

**D-021**  
Attaches évasées 3/4" (50 par boîte)

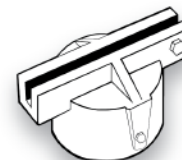
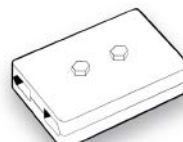
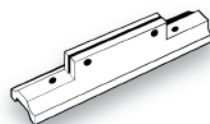
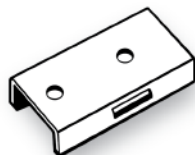

**SU-5**  
Adaptateur pour fixer une enseigne à un poteau rond avec une courroie en acier inoxydable.

**SU-10**  
Adaptateur pour fixer une enseigne à un poteau rond avec une courroie en acier inoxydable ou à un poteau en U avec des boulons.

**SU-16**  
Adaptateur pour fixer deux noms de rue extrusion superposés en parallèle.

**SU-30**  
Adaptateur pour nom de rue extrusion fixé sur poteau rond, aussi disponible pour nom de rue plat.

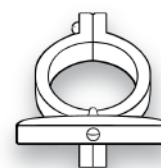

**SU-33**  
Adaptateur de nom de rue extrusion fixé à un poteau télespar.

**SU-40**  
Adaptateur pour deux noms de rue extrusion superposés en croix, aussi disponible pour nom de rue plat.

**SU-70**  
Adaptateur de nom de rue extrusion fixé à un poteau en U, aussi disponible pour nom de rue plat.

**SU-71**  
Adaptateur pour fixer une enseigne à un poteau rond de 2 3/8" de diamètre extérieur.

## POTEAUX

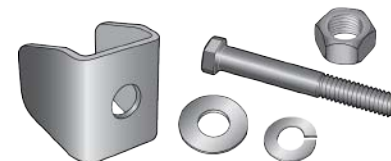
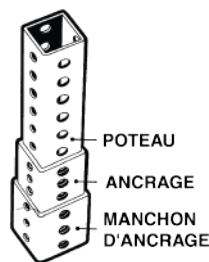
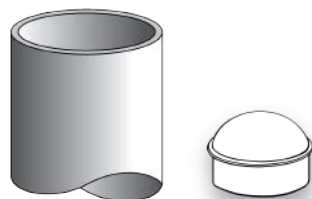

### POTEAUX RONDS

Poteau rond galvanisé

Diamètre extérieur	2 3/8"
Épaisseur de mur	1/8"
Longueur	10,5'

### CAPUCHON

Pour poteau rond

### POTEAUX CARRÉS

Les poteaux carrés sont trouvés sur quatre faces à tous les pouces

LONGUEUR :	Manchons :	18" x 2 1/4" x 2 1/4"
	Ancrage :	36" x 2" x 2"
	Poteau :	8' x 1 3/4" x 1 3/4"
		10' x 1 3/4" x 1 3/4"
		12' x 1 3/4" x 1 3/4"

ACCESSOIRES :	Rivets # TL-3806
	Boulon coudé # TL-070

### ENSEMBLE D'ACCESSOIRES PANNEAU

Un ensemble comprend :

1x espaceur en U galvanisé
1x boulon 3/8" x 2 1/2" ou 2"
1x écrou 3/8"
1x rondelle plate 3/8"
1x rondelle de blocage 3/8"

2 ensembles sont requis pour installer une enseigne



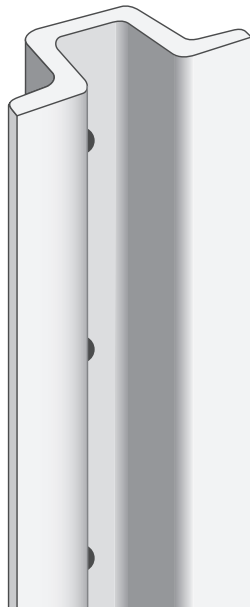

## TYPE-2

*Poteau en acier galvanisé formé à froid d'une épaisseur approximative de ,150".  
Ce poteau est muni de perforations à tous les 2" centre à centre sur toute sa longueur et a un bout effilé.*

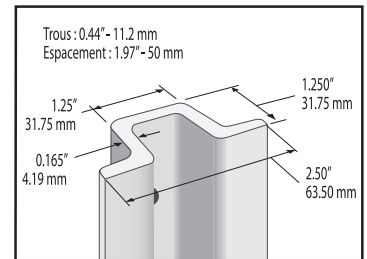

Les dimensions indiquées sont avant la galvanisation.

Longueur		Poids approx. du poteau	
Pieds	Mètres	Livres	Kilogrammes
3	.915	6.39	2.90
4	1.22	8.52	3.86
5	1.52	10.65	4.83
8	2.44	17.04	7.73
10	3.05	21.30	9.66
12	3.66	25.56	11.59

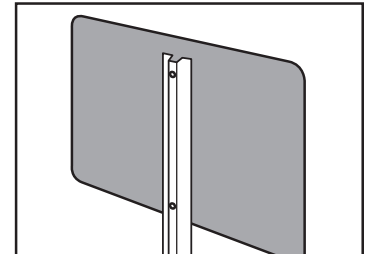

Installation simple et rapide du panneau au poteau

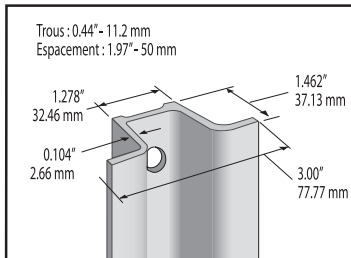

Les dimensions indiquées sont avant la galvanisation.

## TYPE-3

*Poteau en acier galvanisé formé à froid d'une épaisseur approximative de ,120".  
Ce poteau est muni de perforations à tous les 2" centre à centre sur toute sa longueur et a un bout effilé.*

Longueur		Poids approx. du poteau	
Pieds	Mètres	Livres	Kilogrammes
4	1.22	8.40	3.81

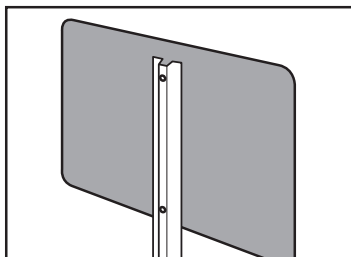

Installation simple et rapide du panneau au poteau

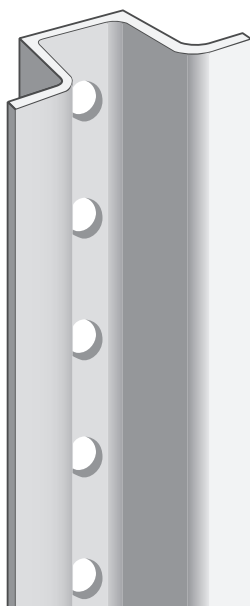
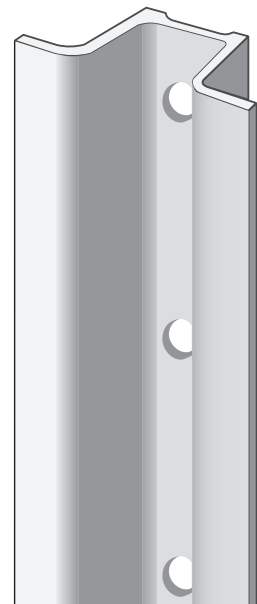

## MINI POST

*Poteau en acier galvanisé formé à froid.  
Ce poteau est muni de perforations à tous les 1" centre à centre sur toute sa longueur.*

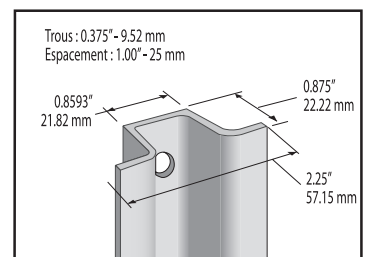

Les dimensions indiquées sont avant la galvanisation.

Longueur		Poids approx. du poteau	
Pieds	Mètres	Livres	Kilogrammes
8	2.44	9.41	4.27

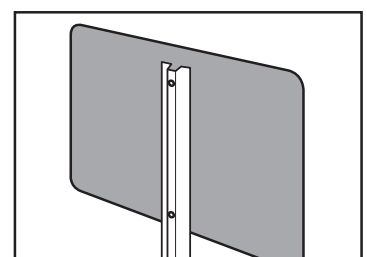

Installation simple et rapide du panneau au poteau

# BASES DE SIGNALISATION EN BÉTON

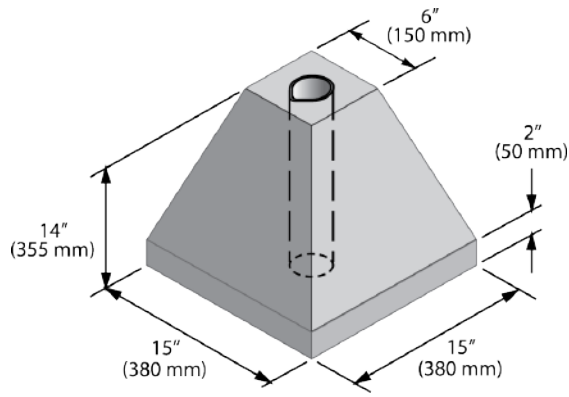

**BASE DE BÉTON PYRAMIDALE**

Pour tuyau de 2" (50 mm)

Poids 115 lb (52 kg)

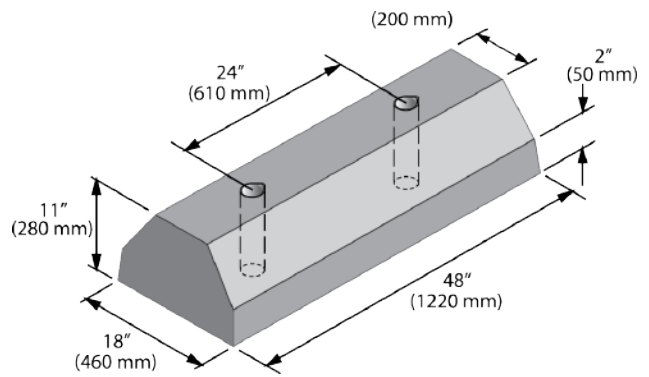

**BASE DE BÉTON RECTANGULAIRE**

Pour tuyau de 2" (50 mm)

Poids 575 lb (260 kg)

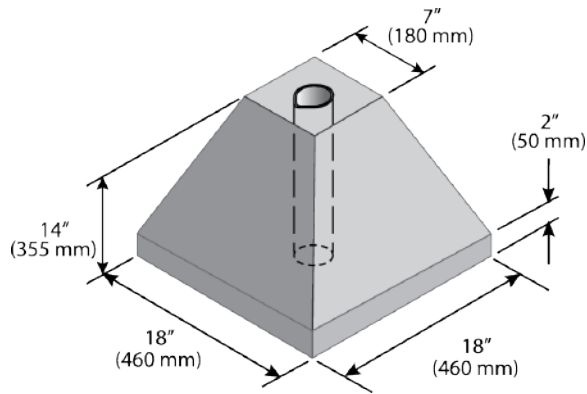

**BASE DE BÉTON PYRAMIDALE**

Pour tuyau de 2" (50 mm)

Poids 200 lb (91 kg)

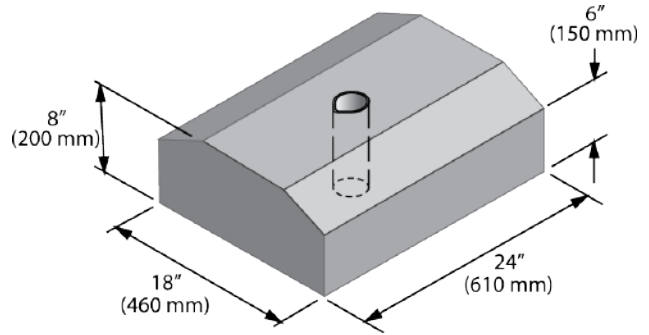

**BASE DE BÉTON RECTANGULAIRE**

Pour tuyau de 2" (50 mm)

Poids 285 lb (130 kg)

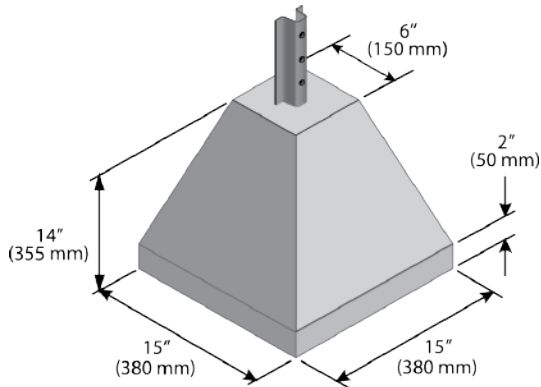

**BASE DE BÉTON PYRAMIDALE : B-115**

Avec poteau en U

Poids 115 lb (52 kg)

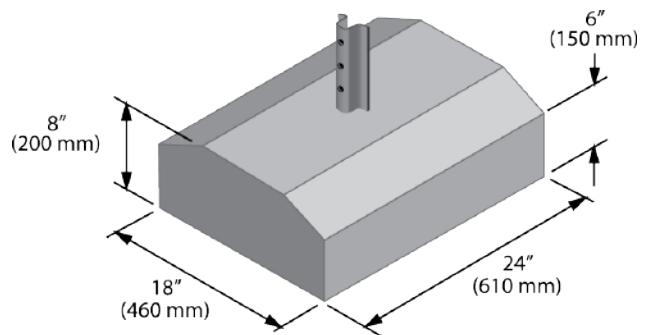

**BASE DE BÉTON RECTANGULAIRE**

Avec poteau en U

Poids 285 lb (130 kg)

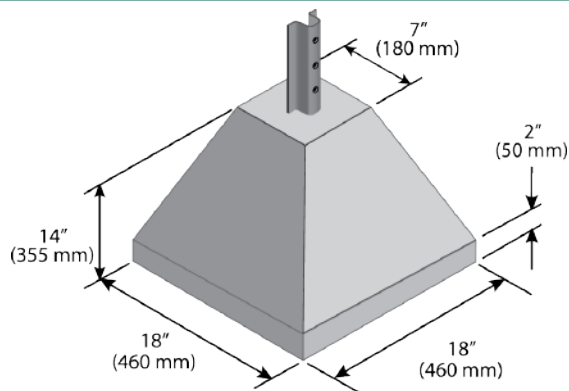

**BASE DE BÉTON PYRAMIDALE**

Avec poteau en U

Poids 200 lb (90 kg)

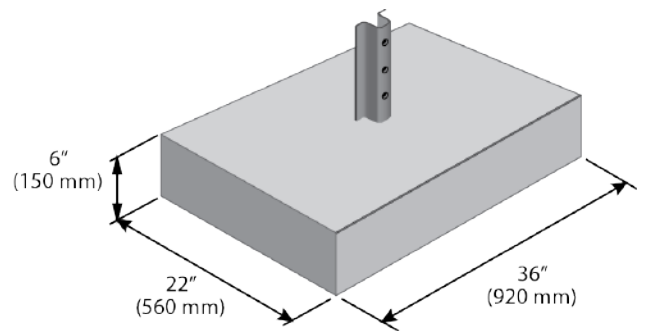

**BASE DE BÉTON RECTANGULAIRE : B-250**

Avec poteau en U

Poids 250 lb (113 kg)

# CS T U O P R



# ÉQUIPEMENT DE SIGNALISATION, SÉCURITÉ ET TRAVAUX

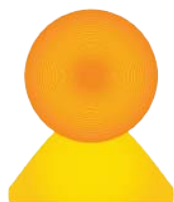

**SZ-101**  
Lumière de barricade



**FLAG-1616**  
Drapeau de signaleur



**SZ-102-2**  
Porte-drapeaux



**SZ-103**  
Bâton de circulation



**SZ-104**  
Casque de sécurité orange pour signaleur



**SZ-105**  
Manteau de signaleur chartreuse (vert)



**SZ-106**  
Pantalon de signaleur chartreuse (vert)



**SZ-111**  
Atténuateur d'impact



**SZ-112**  
Glissière de béton (Jersey) Jonction d'acier Type mâle / femelle



**SZ-113**  
Atténuateur d'impact (Barils)

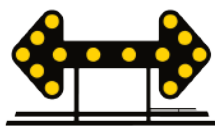

**SZ-114**  
Flèche directionnelle pour camionnette à LED



**SZ-115-P35**  
Base ballioplast (Pesée de 35 lbs)



**SZ-115-PVC-48**  
Poteau 48" en PVC

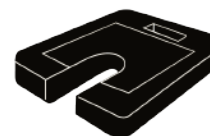

**SZ-115-P50**  
Pesée caoutchouc type U (Pesée de 30, 40 ou 50 lbs)



**SZ-117**  
Poteau type 2 avec base d'acier pour pesée en U



**SZ-118**  
Dos d'âne / ralentisseur

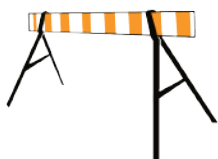

**SZ-119**  
Support en acier pour T-B-01



**SZ-120**  
Whip de sécurité avec ressort pour camionnette



**SZ-121**  
Pattes pour T-B-02



**SZ-122**  
Barricade pliante pour enseigne 600 x 600 mm (enseigne non-comprise)



**SZ-123**  
Enseigne en crézon avec pentures, chaînes et poignée (utilis pour travaux temporaires) 600X800 MM



**SZ-124**  
Barricade anti-foule



**SZ-125**  
Balise Cyclo-Zone pour piste cyclable



**SZ-126**  
Panneau de coroplast noir avec bande orange diamant pour couvrir les panneaux sur les chantiers (600 x 600 mm ou 750 x 750 mm)



**SZ-127**  
Balise amovible

## BALISES ROUTIÈRES ET CÔNES



**TRV-1**  
Chevron 600X750X2.1 MM



**TRV-2**  
Balise 300X900X2.1 MM



**TRV-3**  
Cône en PVC 28", 18" ou 12"



**TRV-4**  
Fusée de sécurité

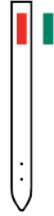

**TRV-5-HR / TRV-5-HV**  
Balise flexible rouge ou verte  
60" haut



**TRV-6**  
Baril cône 36"



**TRV-7**  
Baril cône 52"



**TRV-8**  
Balise



**TRV-9**  
Balise



**TRV-10**  
Bollard avec base vissée

## DIVERS



**SZ-107**  
Panneau à messages variables sur remorque



**SZ-108**  
Remorque flèche avec panneau solaire



**SZ-109**  
Flèche directionnelle portable à LEDS



**SZ-110**  
Feux de chantier avec décompte

# PANNEAUX D'ALUMINIUM

## FORMES STANDARDS

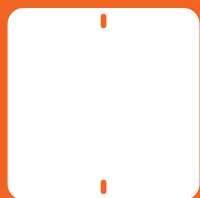

**Dimensions**

mm

300 x 300

450 x 450

600 x 600

750 x 750

900 x 900

1200 x 1200

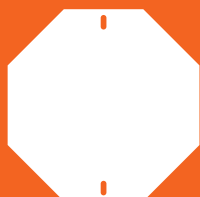

600 x 600

900 x 900

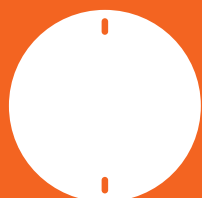

300 x 300

450 x 450

600 x 600

750 x 750

900 x 900



600 x 600 x 600

750 x 750 x 750

900 x 900 x 900

1200 x 1200 x 1200



**Dimensions**

mm

300 x 375

300 x 450

300 x 600

300 x 900

450 x 600

600 x 750

600 x 900

600 x 1200

900 x 1200



# CNC

Nous offrons un service de découpe à la CNC qui nous permet de découper toutes sortes de formes personnalisées.

## FORMES PERSONNALISÉES





**ET PLUS ENCORE...!**

# WALK SAFE WITH PPE TRA



## FORMES ET COULEURS DES PANNEAUX

selon les normes du Ministère des Transports du Québec

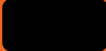
Forme	Couleur	Description
	Orange	Réservé aux travaux
	Orange	Travaux
	Orange	Travaux
	Orange	Travaux





T-010	T-020	T-030	T-040	T-050-1	T-050-2
<i>Panneau du signaleur</i>	<i>Signal avancé avant travaux</i>	<i>Étendue des travaux</i>	<i>Fin des travaux</i>	<i>Hommes au travail</i>	<i>Arpentage</i>
450 x 450 mm 600 x 600 mm	600 x 600 mm 750 x 750 mm 900 x 900 mm 1200 x 1200 mm	600 x 600 mm 750 x 750 mm 900 x 900 mm 1200 x 1200 mm	600 x 600 mm 750 x 750 mm 900 x 900 mm 1200 x 1200 mm	600 x 600 mm 750 x 750 mm 900 x 900 mm 1200 x 1200 mm	600 x 600 mm 750 x 750 mm 900 x 900 mm 1200 x 1200 mm



T-050-3	T-050-4	T-050-5	T-050-6	T-050-7	T-050-8
<i>Travaux en hauteur</i>	<i>Travaux mécanisés</i>	<i>Contrôle transport routier</i>	<i>Niveleuse</i>	<i>Activités sportives</i>	<i>Mesures d'urgence</i>
600 x 600 mm 750 x 750 mm 900 x 900 mm 1200 x 1200 mm	600 x 600 mm 750 x 750 mm 900 x 900 mm 1200 x 1200 mm	600 x 600 mm 750 x 750 mm 900 x 900 mm 1200 x 1200 mm	600 x 600 mm 750 x 750 mm 900 x 900 mm 1200 x 1200 mm	600 x 600 mm 750 x 750 mm 900 x 900 mm 1200 x 1200 mm	600 x 600 mm 750 x 750 mm 900 x 900 mm 1200 x 1200 mm



T-050-9	T-060	T-070-1	T-070-1-30	T-070-1-40	T-070-1-50
<i>Souffleuse</i>	<i>Signal avancé signaleur</i>	<i>Limite de vitesse</i>	<i>Limite de vitesse</i>	<i>Limite de vitesse</i>	<i>Limite de vitesse</i>
600 x 600 mm 750 x 750 mm 900 x 900 mm 1200 x 1200 mm	600 x 600 mm 750 x 750 mm 900 x 900 mm 1200 x 1200 mm	600 x 750 mm 900 x 1200 mm	600 x 750 mm 900 x 1200 mm	600 x 750 mm 900 x 1200 mm	600 x 750 mm 900 x 1200 mm



T-070-1-60	T-070-1-70	T-070-1-80	T-070-1-90	T-070-2	T-070-2-30
<i>Limite de vitesse</i>	<i>Limite de vitesse</i>	<i>Limite de vitesse</i>	<i>Limite de vitesse</i>	<i>Signal avancé limite vitesse</i>	<i>Signal avancé limite vitesse</i>
600 x 750 mm 900 x 1200 mm	600 x 750 mm 900 x 1200 mm	600 x 750 mm 900 x 1200 mm	600 x 750 mm 900 x 1200 mm	600 x 600 mm 750 x 750 mm 900 x 900 mm 1200 x 1200 mm	600 x 600 mm 750 x 750 mm 900 x 900 mm 1200 x 1200 mm



T-070-2-50	T-070-2-70	T-075	T-075-D	T-075-G	T-075-G-D
<i>Signal avancé limite vitesse</i>	<i>Signal avancé limite vitesse</i>	<i>Règ. temporaire stationnement</i>	<i>Règ. temporaire stationnement</i>	<i>Règ. temporaire stationnement</i>	<i>Règ. temporaire stationnement</i>
600 x 600 mm 750 x 750 mm 900 x 900 mm 1200 x 1200 mm	600 x 600 mm 750 x 750 mm 900 x 900 mm 1200 x 1200 mm	300 x 450 mm	300 x 450 mm	300 x 450 mm	300 x 450 mm



T-080-1	T-080-2	T-080-3	T-080-4	T-080-5	T-080-6
Temporairement fermée	Temporairement fermée	Temporairement fermé	Temporairement fermée	Temporairement fermé	Temporairement fermé
600 x 600 mm	600 x 600 mm	600 x 600 mm	600 x 600 mm	600 x 600 mm	600 x 600 mm
750 x 750 mm	750 x 750 mm	750 x 750 mm	750 x 750 mm	750 x 750 mm	750 x 750 mm
900 x 900 mm	900 x 900 mm	900 x 900 mm	900 x 900 mm	900 x 900 mm	900 x 900 mm
1200 x 1200 mm	1200 x 1200 mm	1200 x 1200 mm	1200 x 1200 mm	1200 x 1200 mm	1200 x 1200 mm



T-080-7	T-080-P	T-085-1	T-085-2	T-085-4	T-085-5
Temporairement fermé	Circulation locale seulement	Signal avancé route barrée	Signal avancé rue barrée	Signal avancé sortie barrée	Signal avancé pont barré
750 x 380 mm	600 x 600 mm	600 x 600 mm	600 x 600 mm	600 x 600 mm	600 x 600 mm
900 x 450 mm	750 x 750 mm	750 x 750 mm	750 x 750 mm	750 x 750 mm	750 x 750 mm
1200 x 600 mm	900 x 900 mm	900 x 900 mm	900 x 900 mm	900 x 900 mm	900 x 900 mm
	1200 x 1200 mm	1200 x 1200 mm	1200 x 1200 mm	1200 x 1200 mm	1200 x 1200 mm



T-085-6	T-090-1	T-090-2-D	T-090-2-G	T-090-3-D	T-090-3-G
Signal avancé tunnel barré	Détour tout droit	Détour à droite	Détour à gauche	Détour à droite	Détour à gauche
600 x 600 mm	600 x 600 mm	600 x 600 mm	600 x 600 mm	600 x 600 mm	600 x 600 mm
750 x 750 mm	750 x 750 mm	750 x 750 mm	750 x 750 mm	750 x 750 mm	750 x 750 mm
900 x 900 mm	900 x 900 mm	900 x 900 mm	900 x 900 mm	900 x 900 mm	900 x 900 mm
1200 x 1200 mm	1200 x 1200 mm	1200 x 1200 mm	1200 x 1200 mm	1200 x 1200 mm	1200 x 1200 mm



T-090-4	T-090-10-D	T-090-10-G	T-100-1-D	T-100-1-G	T-100-2-D
Détour via	Détour à droite	Détour à gauche	Fusion de voies à droite	Fusion de voies à gauche	Fusion de voies à droite
3000 x 1830	600 x 600 mm	600 x 600 mm	600 x 600 mm	600 x 600 mm	600 x 600 mm
	750 x 750 mm	750 x 750 mm	750 x 750 mm	750 x 750 mm	750 x 750 mm
	900 x 900 mm	900 x 900 mm	900 x 900 mm	900 x 900 mm	900 x 900 mm
	1200 x 1200 mm	1200 x 1200 mm	1200 x 1200 mm	1200 x 1200 mm	1200 x 1200 mm



T-100-2-G	T-100-3-D	T-100-3-G	T-100-4-D	T-100-4-G	T-110-1-D
Fusion de voies à gauche	Fusion de voies à droite	Fusion de voies à gauche	Fusion de voies à droite	Fusion de voies à gauche	Déviations de voie à droite
600 x 600 mm	600 x 600 mm	600 x 600 mm	600 x 600 mm	600 x 600 mm	600 x 600 mm
750 x 750 mm	750 x 750 mm	750 x 750 mm	750 x 750 mm	750 x 750 mm	750 x 750 mm
900 x 900 mm	900 x 900 mm	900 x 900 mm	900 x 900 mm	900 x 900 mm	900 x 900 mm
1200 x 1200 mm	1200 x 1200 mm	1200 x 1200 mm	1200 x 1200 mm	1200 x 1200 mm	1200 x 1200 mm



T-110-1-G	T-110-2-D	T-110-2-G	T-110-3-D	T-110-3-G	T-110-4-D
Déviation de voie à gauche	Déviation de voies à droite	Déviation de voies à gauche	Déviation/Division des voies	Déviation/Division des voies	Déviation vers la droite
600 x 600 mm	600 x 600 mm	600 x 600 mm	600 x 600 mm	600 x 600 mm	600 x 600 mm
750 x 750 mm	750 x 750 mm	750 x 750 mm	750 x 750 mm	750 x 750 mm	750 x 750 mm
900 x 900 mm	900 x 900 mm	900 x 900 mm	900 x 900 mm	900 x 900 mm	900 x 900 mm
1200 x 1200 mm	1200 x 1200 mm	1200 x 1200 mm	1200 x 1200 mm	1200 x 1200 mm	1200 x 1200 mm



T-110-4-G	T-110-5-D	T-110-5-G	T-110-6	T-110-7-D	T-110-7-G
Déviation vers la gauche	Déviation vers la droite	Déviation vers la gauche	Déviation gauche et droite	Déviation vers la droite	Déviation vers la gauche
600 x 600 mm	600 x 600 mm	600 x 600 mm	600 x 600 mm	600 x 600 mm	600 x 600 mm
750 x 750 mm	750 x 750 mm	750 x 750 mm	750 x 750 mm	750 x 750 mm	750 x 750 mm
900 x 900 mm	900 x 900 mm	900 x 900 mm	900 x 900 mm	900 x 900 mm	900 x 900 mm
1200 x 1200 mm	1200 x 1200 mm	1200 x 1200 mm	1200 x 1200 mm	1200 x 1200 mm	1200 x 1200 mm



T-110-8-D	T-110-8-G	T-110-9-D	T-110-9-G	T-110-P	T-110-P-15
Déviation vers la droite	Déviation vers la gauche	Déviation vers la droite	Déviation vers la gauche	Vitesse recommandée	Vitesse recommandée
600 x 600 mm	600 x 600 mm	600 x 600 mm	600 x 600 mm	450 x 450 mm	450 x 450 mm
750 x 750 mm	750 x 750 mm	750 x 750 mm	750 x 750 mm	900 x 900 mm	900 x 900 mm
900 x 900 mm	900 x 900 mm	900 x 900 mm	900 x 900 mm		
1200 x 1200 mm	1200 x 1200 mm	1200 x 1200 mm	1200 x 1200 mm		



T-110-P-25	T-110-P-35	T-110-P-45	T-110-P-55	T-110-P-65	T-110-P-75
Vitesse recommandée	Vitesse recommandée	Vitesse recommandée	Vitesse recommandée	Vitesse recommandée	Vitesse recommandée
450 x 450 mm	450 x 450 mm	450 x 450 mm	450 x 450 mm	450 x 450 mm	450 x 450 mm
900 x 900 mm	900 x 900 mm	900 x 900 mm	900 x 900 mm	900 x 900 mm	900 x 900 mm



T-110-P-85	T-120	T-130	T-140-D	T-140-G	T-150
Vitesse recommandée	Flèche oblique	Balise à chevron	Accotement surbaissé à droite	Accotement surbaissé à gauche	Dynamitage
450 x 450 mm	600 x 600 mm	600 x 900 mm	600 x 600 mm	600 x 600 mm	600 x 600 mm
900 x 900 mm	750 x 750 mm	1200 x 1800 mm	750 x 750 mm	750 x 750 mm	750 x 750 mm
	900 x 900 mm		900 x 900 mm	900 x 900 mm	900 x 900 mm
	1200 x 1200 mm		1200 x 1200 mm	1200 x 1200 mm	1200 x 1200 mm



**PEINTURE  
FRAÎCHE**

**ENQUÊTE DE  
CIRCULATION**

**MERCI**

**ACCÈS AU  
CHANTIER**  
X ↘

**ACCÈS AU  
CHANTIER**  
↙ X

T-160-1	T-160-2	T-170-1	T-170-2	T-170-4-D	T-170-4-G
<i>Travaux de marquage</i>	<i>Travaux de marquage</i>	<i>Enquête de circulation</i>	<i>Merci</i>	<i>Accès au chantier à droite</i>	<i>Accès au chantier à gauche</i>
600 x 600 mm	1500 x 750	1200 x 600 mm	750 x 380 mm	600 x 600 mm	600 x 600 mm
750 x 750 mm			900 x 450 mm	750 x 750 mm	750 x 750 mm
900 x 900 mm			1200 x 600 mm	900 x 900 mm	900 x 900 mm
1200 x 1200 mm				1200 x 1200 mm	1200 x 1200 mm

**CIRCULATION  
AVEC  
VÉHICULE  
ESCORTE**



**CIRCULATION  
PERMISE  
SUR  
ACCOTEMENT**

**CIRCULATION  
INTERDITE  
SUR  
ACCOTEMENT**

**FIN DE  
CIRCULATION  
SUR  
ACCOTEMENT**

T-170-5	T-180	T-190	T-200-1	T-200-2	T-200-3
<i>Véhicule escorte</i>	<i>Dégagement horizontal</i>	<i>Projection de matériaux</i>	<i>Circulation permise sur accotement</i>	<i>Circulation interdite sur accotement</i>	<i>Fin de circulation sur accotement</i>
750 x 750 mm	600 x 600 mm	600 x 600 mm	750 x 750 mm	750 x 750 mm	750 x 750 mm
900 x 900 mm	750 x 750 mm	750 x 750 mm	900 x 900 mm	900 x 900 mm	900 x 900 mm
1200 x 1200 mm	900 x 900 mm	900 x 900 mm	1200 x 1200 mm	1200 x 1200 mm	1200 x 1200 mm
	1200 x 1200 mm	1200 x 1200 mm			

**TRAVAUX**  
AAA  
**MOIS À MOIS**

**TEMPS  
D'ATTENTE  
MAX XX SEC.**



T-210	T-220	T-230	T-240	T-240-P-10-G	T-240-P-10-D
<i>Durée des travaux</i>	<i>Temps d'attente</i>	<i>Congestion</i>	<i>Fréquence radio</i>	<i>Emplacement d'un passage</i>	<i>Emplacement d'un passage</i>
3000 x 2135 mm	750 x 750 mm	900 x 900 mm	750 x 750 mm	600 x 300 mm	600 x 300 mm
	900 x 900 mm		900 x 900 mm	750 x 380 mm	750 x 380 mm
	1200 x 1200 mm		1200 x 1200 mm	900 x 450 mm	900 x 450 mm
				1200 x 600 mm	1200 x 600 mm

**XXX m →**

**← XXX m**

**XXX m**

**X km**

**XX km**

**SUR XXX m**

T-240-P-11-D	T-240-P-11-G	T-245-P-2	T-245-P-3	T-245-P-4	T-250-P-2
<i>Distance et direction</i>	<i>Distance et direction</i>	<i>Distance</i>	<i>Distance</i>	<i>Distance</i>	<i>Étendue</i>
600 x 300 mm	600 x 300 mm	300 x 150 mm	600 x 300 mm	750 x 380 mm	300 x 150 mm
900 x 450 mm	900 x 450 mm	750 x 380 mm	750 x 380 mm	900 x 450 mm	750 x 380 mm
1200 x 600 mm	1200 x 600 mm	900 x 450 mm	900 x 450 mm	1200 x 600 mm	900 x 450 mm
		1200 x 600 mm	1200 x 600 mm		1200 x 600 mm

**SUR X km**

**SUR XX km**



T-250-P-3	T-250-P-4	T-B-01	T-B-02	T-D-010-1	T-D-030
<i>Étendue</i>	<i>Étendue</i>	<i>Barrière</i>	<i>Barrière</i>	<i>Signal avancé d'arrêt</i>	<i>Signal avancé de cédez</i>
300 x 150 mm	300 x 150 mm	1800 x 140 mm		600 x 600 mm	600 x 600 mm
750 x 380 mm	750 x 380 mm			750 x 750 mm	750 x 750 mm
900 x 450 mm	900 x 450 mm			900 x 900 mm	900 x 900 mm
1200 x 600 mm	1200 x 600 mm			1200 x 1200 mm	1200 x 1200 mm



VOIE DE GAUCHE

T-D-050	T-D-080	T-D-090-3	T-D-100-2-D	T-D-100-2-G	T-D-100-2-P-1
Signal avancé feux circ.	Signal avancé circ. deux sens	Chaussées séparées	Signal avancé dir. des voies	Signal avancé dir. des voies	Voie de gauche
600 x 600 mm	600 x 600 mm	600 x 600 mm	600 x 600 mm	600 x 600 mm	750 x 380 mm
750 x 750 mm	750 x 750 mm	750 x 750 mm	750 x 750 mm	750 x 750 mm	900 x 450 mm
900 x 900 mm	900 x 900 mm	900 x 900 mm	900 x 900 mm	900 x 900 mm	1200 x 600 mm
1200 x 1200 mm	1200 x 1200 mm	1200 x 1200 mm	1200 x 1200 mm	1200 x 1200 mm	

VOIE DE DROITE



T-D-100-2-P-2	T-D-100-6-D	T-D-100-6-G	T-D-100-8-D	T-D-100-8-G	T-D-110-1-D
Voie de droite	Signal avancé dir. des voies	Signal avancé dir. des voies	Signal avancé dir. des voies	Signal avancé dir. des voies	Virage à droite 90°
750 x 380 mm	600 x 600 mm	600 x 600 mm	600 x 600 mm	600 x 600 mm	600 x 600 mm
900 x 450 mm	750 x 750 mm	750 x 750 mm	750 x 750 mm	750 x 750 mm	750 x 750 mm
1200 x 600 mm	900 x 900 mm	900 x 900 mm	900 x 900 mm	900 x 900 mm	900 x 900 mm
	1200 x 1200 mm	1200 x 1200 mm	1200 x 1200 mm	1200 x 1200 mm	1200 x 1200 mm



T-D-110-1-G	T-D-110-2-D	T-D-110-2-G	T-D-130-1-D	T-D-130-1-G	T-D-130-2
Virage à droite 90°	Virage à droite 45°	Virage à droite 45°	Flèche directionnelle	Flèche directionnelle	Flèche bidirectionnelle
600 x 600 mm	600 x 600 mm	600 x 600 mm	600 x 600 mm	600 x 600 mm	600 x 600 mm
750 x 750 mm	750 x 750 mm	750 x 750 mm	750 x 750 mm	750 x 750 mm	750 x 750 mm
900 x 900 mm	900 x 900 mm	900 x 900 mm	900 x 900 mm	900 x 900 mm	900 x 900 mm
1200 x 1200 mm	1200 x 1200 mm	1200 x 1200 mm	1200 x 1200 mm	1200 x 1200 mm	1200 x 1200 mm



T-D-140-1	T-D-170-1	T-D-170-2	T-D-170-3	T-D-190-1	T-D-190-2
Voie convergente	Intersection en croix	Intersection en T	Intersection gauche ou droite	Signal avancé limit. hauteur	Limitation de hauteur
600 x 600 mm	600 x 600 mm	600 x 600 mm	600 x 600 mm	600 x 600 mm	600 x 600 mm
750 x 750 mm	750 x 750 mm	750 x 750 mm	750 x 750 mm	750 x 750 mm	750 x 750 mm
900 x 900 mm	900 x 900 mm	900 x 900 mm	900 x 900 mm	900 x 900 mm	900 x 900 mm
1200 x 1200 mm	1200 x 1200 mm	1200 x 1200 mm	1200 x 1200 mm	1200 x 1200 mm	1200 x 1200 mm



T-D-200	T-D-210-1	T-D-210-2-D	T-D-210-2-G	T-D-270-11-D	T-D-270-11-G
Passage étroit	Chaussée rétrécie	Chaussée rétrécie à droite	Chaussée rétrécie à gauche	Passage pour camion	Passage pour camion
600 x 600 mm	600 x 600 mm	600 x 600 mm	600 x 600 mm	600 x 600 mm	600 x 600 mm
750 x 750 mm	750 x 750 mm	750 x 750 mm	750 x 750 mm	750 x 750 mm	750 x 750 mm
900 x 900 mm	900 x 900 mm	900 x 900 mm	900 x 900 mm	900 x 900 mm	900 x 900 mm
1200 x 1200 mm	1200 x 1200 mm	1200 x 1200 mm	1200 x 1200 mm	1200 x 1200 mm	1200 x 1200 mm



T-D-280	T-D-310-1	T-D-340	T-D-350	T-D-360
<i>Fin de voie ou chemin</i>	<i>Chaussée glissante</i>	<i>Changement état chaussée</i>	<i>Fin du revêtement</i>	<i>Chaussée cahoteuse</i>
600 x 600 mm	600 x 600 mm	600 x 600 mm	600 x 600 mm	600 x 600 mm
750 x 750 mm	750 x 750 mm	750 x 750 mm	750 x 750 mm	750 x 750 mm
900 x 900 mm	900 x 900 mm	900 x 900 mm	900 x 900 mm	900 x 900 mm
1200 x 1200 mm	1200 x 1200 mm	1200 x 1200 mm	1200 x 1200 mm	1200 x 1200 mm

## MONTAGE SUR VÉHICULES D'ACCOMPAGNEMENT



TM-50-1	TM-50-3	TM-100-1-G	TM-100-1-D	TM-100-2-G
1700 x 1700 mm	1700 x 1700 mm	1700 x 1700 mm	1700 x 1700 mm	1700 x 1700 mm







TM-100-2-D	TM-100-3-G	TM-100-3-D	TM-160-1	TM-230
1700 x 1700 mm	1700 x 1700 mm	1700 x 1700 mm	1700 x 1700 mm	1700 x 1700 mm

# PRESCRIPTION



## FORMES ET COULEURS DES PANNEAUX

selon les normes du Ministère des Transports du Québec

Forme	Couleur	Description
	Rouge	Réservé à l'arrêt
	Rouge et blanc	Réservé au cédez
	Blanc et noir	Au sol et au dessus des voies
	Blanc	au sol
	Noir	Réservé au sens unique



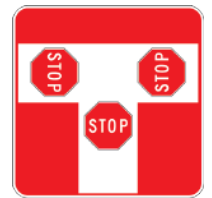
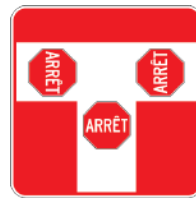
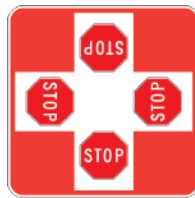
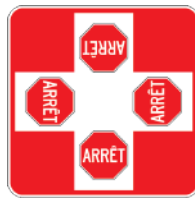

P-010	P-010-S	P-010-P-1	P-010-P-1-S	P-010-P-2	P-010-P-2-S
Arrêt	Stop	Panonceau Arrêt	Panonceau Stop	Panonceau Arrêt	Panonceau Stop
450 x 450 mm	450 x 450 mm	450 x 450 mm	450 x 450 mm	450 x 450 mm	450 x 450 mm
600 x 600 mm	600 x 600 mm	600 x 600 mm	600 x 600 mm	600 x 600 mm	600 x 600 mm
750 x 750 mm	750 x 750 mm	750 x 750 mm	750 x 750 mm	750 x 750 mm	750 x 750 mm
900 x 900 mm	900 x 900 mm	900 x 900 mm	900 x 900 mm	900 x 900 mm	900 x 900 mm
1200 x 1200 mm	1200 x 1200 mm				



P-010-P-3	P-010-P-3-S	P-020-1	P-020-2	P-030	P-040
Panonceau Arrêt	Panonceau Stop	Cédez le passage	Cédez le passage	Cédez à la circulation inverse	Entrée interdite
450 x 450 mm	450 x 450 mm	450 x 450 mm	450 x 450 mm	600 x 750 mm	300 x 300 mm
600 x 600 mm	600 x 600 mm	600 x 600 mm	600 x 600 mm	900 x 1200 mm	600 x 600 mm
750 x 750 mm	750 x 750 mm	750 x 750 mm	750 x 750 mm		900 x 900 mm
900 x 900 mm	900 x 900 mm	900 x 900 mm	900 x 900 mm		1200 x 1200 mm



P-040-P	P-060-D	P-060-G	P-070-1	P-070-2	P-070-2-10
Entrée interdite	Ligne d'arrêt	Ligne d'arrêt	Limite de vitesse	Limite de vitesse	Limite de vitesse
300 x 150 mm	600 x 750 mm	600 x 750 mm	900 x 1200 mm	300 x 375 mm	300 x 375 mm
600 x 300 mm	900 x 1200 mm	900 x 1200 mm		600 x 750 mm	600 x 750 mm
750 x 375 mm				900 x 1200 mm	900 x 1200 mm
900 x 450 mm					
1200 x 600 mm					



P-070-2-20	P-070-2-30	P-070-2-40	P-070-2-50	P-070-2-60	P-070-2-70
Limite de vitesse	Limite de vitesse	Limite de vitesse	Limite de vitesse	Limite de vitesse	Limite de vitesse
300 x 375 mm	300 x 375 mm	300 x 375 mm	300 x 375 mm	300 x 375 mm	300 x 375 mm
600 x 750 mm	600 x 750 mm	600 x 750 mm	600 x 750 mm	600 x 750 mm	600 x 750 mm
900 x 1200 mm	900 x 1200 mm	900 x 1200 mm	900 x 1200 mm	900 x 1200 mm	900 x 1200 mm



P-070-2-80	P-070-2-90	P-070-2-100	P-070-3	P-070-4	P-080-1
Limite de vitesse	Limite de vitesse	Limite de vitesse	Limite de vitesse	Limite de vitesse	Sens unique
300 x 375 mm	300 x 375 mm	300 x 375 mm	600 x 750 mm	300 x 375 mm	450 x 150 mm
600 x 750 mm	600 x 750 mm	600 x 750 mm	900 x 1200 mm	600 x 750 mm	750 x 250 mm
900 x 1200 mm	900 x 1200 mm	900 x 1200 mm		900 x 1200 mm	900 x 300 mm



<b>P-080-2</b>	<b>P-080-3</b>	<b>P-090-D</b>	<b>P-090-G</b>	<b>P-090-G-D</b>	<b>P-100-1</b>
<i>Debut sens unique</i>	<i>Circulation à double sens</i>	<i>Contournement d'obstacle</i>	<i>Contournement d'obstacle</i>	<i>Contournement d'obstacle</i>	<i>Direction des voies</i>
600 x 750 mm	300 x 375 mm	300 x 375 mm	300 x 375 mm	300 x 375 mm	600 x 600 mm
900 x 1200 mm	600 x 750 mm	600 x 750 mm	600 x 750 mm	600 x 750 mm	750 x 750 mm
	900 x 1200 mm	900 x 1200 mm	900 x 1200 mm	900 x 1200 mm	900 x 900 mm
					1200 x 1200 mm



<b>P-100-2-D</b>	<b>P-100-2-G</b>	<b>P-100-2-P-1</b>	<b>P-100-2-P-2</b>	<b>P-100-3-D</b>	<b>P-100-3-G</b>
<i>Direction des voies</i>	<i>Direction des voies</i>	<i>Voie de gauche</i>	<i>Voie de droite</i>	<i>Direction des voies</i>	<i>Direction des voies</i>
600 x 600 mm	600 x 600 mm	900 x 450 mm	900 x 450 mm	600 x 600 mm	600 x 600 mm
900 x 900 mm	900 x 900 mm	1200 x 600 mm	1200 x 600 mm	750 x 750 mm	750 x 750 mm
1200 x 1200 mm	1200 x 1200 mm			900 x 900 mm	900 x 900 mm
				1200 x 1200 mm	1200 x 1200 mm

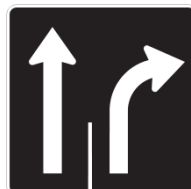
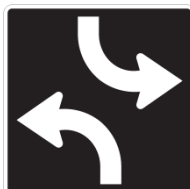

<b>P-100-4</b>	<b>P-100-5</b>	<b>P-100-5-P</b>	<b>P-100-6-D</b>	<b>P-100-6-G</b>	<b>P-100-6-G-D</b>
<i>Direction des voies</i>	<i>Direction des voies</i>	<i>Voie du centre</i>	<i>Direction des voies</i>	<i>Direction des voies</i>	<i>Direction des voies</i>
900 x 900 mm	750 x 750 mm	750 x 375 mm	600 x 600 mm	600 x 600 mm	600 x 600 mm
1200 x 1200 mm	900 x 900 mm	900 x 450 mm	750 x 750 mm	750 x 750 mm	750 x 750 mm
	1200 x 1200 mm	1200 x 600 mm	900 x 900 mm	900 x 900 mm	900 x 900 mm
			1200 x 1200 mm	1200 x 1200 mm	1200 x 1200 mm

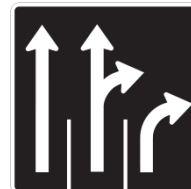
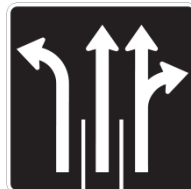
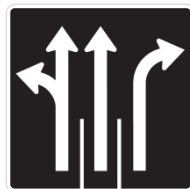
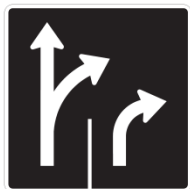

<b>P-100-7-D</b>	<b>P-100-7-G</b>	<b>P-100-8-A</b>	<b>P-100-8-B</b>	<b>P-100-8-C-D</b>	<b>P-100-8-C-G</b>
<i>Direction des voies</i>	<i>Direction des voies</i>	<i>Direction des voies</i>	<i>Direction des voies</i>	<i>Direction des voies</i>	<i>Direction des voies</i>
900 x 900 mm	900 x 900 mm	750 x 750 mm	750 x 750 mm	900 x 900 mm	900 x 900 mm
1200 x 1200 mm	1200 x 1200 mm	900 x 900 mm	900 x 900 mm	1200 x 1200 mm	1200 x 1200 mm
		1200 x 1200 mm	1200 x 1200 mm		

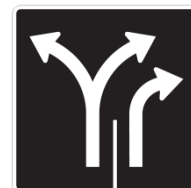
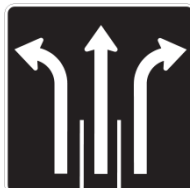
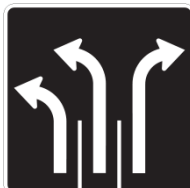
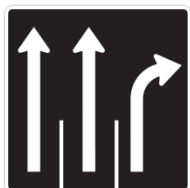

<b>P-100-8-D</b>	<b>P-100-8-E</b>	<b>P-100-8-F</b>	<b>P-100-8-G</b>	<b>P-100-8-H-D</b>	<b>P-100-8-H-G</b>
<i>Direction des voies</i>	<i>Direction des voies</i>	<i>Direction des voies</i>	<i>Direction des voies</i>	<i>Direction des voies</i>	<i>Direction des voies</i>
750 x 750 mm	900 x 900 mm	900 x 900 mm	750 x 750 mm	750 x 750 mm	750 x 750 mm
900 x 900 mm	1200 x 1200 mm	1200 x 1200 mm	900 x 900 mm	900 x 900 mm	900 x 900 mm
1200 x 1200 mm			1200 x 1200 mm	1200 x 1200 mm	1200 x 1200 mm



P-100-8-I

Direction des voies

900 x 900 mm  
1200 x 1200 mm

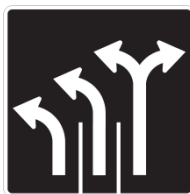

P-100-8-J

Direction des voies

900 x 900 mm  
1200 x 1200 mm



P-100-8-K

Direction des voies

900 x 900 mm  
1200 x 1200 mm



P-100-8-L

Direction des voies

900 x 900 mm  
1200 x 1200 mm

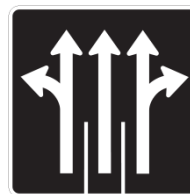

P-100-8-M

Direction des voies

900 x 900 mm  
1200 x 1200 mm

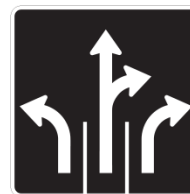

P-100-8-N

Direction des voies

900 x 900 mm  
1200 x 1200 mm



P-100-9-D

Direction des voies

600 x 600 mm  
750 x 750 mm  
900 x 900 mm  
1200 x 1200 mm



P-100-9-G

Direction des voies

600 x 600 mm  
750 x 750 mm  
900 x 900 mm  
1200 x 1200 mm

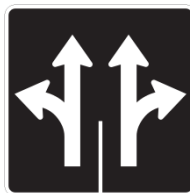

P-100-9-G-D

Direction des voies

600 x 600 mm  
750 x 750 mm  
900 x 900 mm  
1200 x 1200 mm

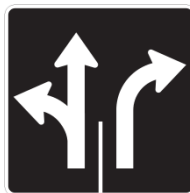

P-100-10-D

Direction des voies

600 x 600 mm  
750 x 750 mm  
900 x 900 mm  
1200 x 1200 mm

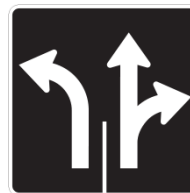

P-100-10-G

Direction des voies

600 x 600 mm  
750 x 750 mm  
900 x 900 mm  
1200 x 1200 mm

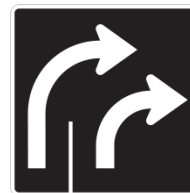

P-100-11-D

Direction des voies

900 x 900 mm  
1200 x 1200 mm



P-100-11-G

Direction des voies

900 x 900 mm  
1200 x 1200 mm



P-100-11-P-1

Voies de gauche

900 x 450 mm  
1200 x 600 mm



P-100-11-P-2

Voies de droite

900 x 450 mm  
1200 x 600 mm

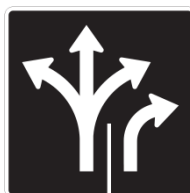

P-100-12-D

Direction des voies

900 x 900 mm  
1200 x 1200 mm



P-100-12-G

Direction des voies

900 x 900 mm  
1200 x 1200 mm



P-100-13

Voies adj. une voie alternée

900 x 900 mm



P-100-14

Voies adj. une voie alternée

900 x 900 mm



P-110-1

Obligation d'aller tout droit

600 x 600 mm  
750 x 750 mm  
900 x 900 mm



P-110-2-D

Obligation d'aller à droite

300 x 300 mm  
450 x 450 mm  
600 x 600 mm  
750 x 750 mm  
900 x 900 mm



P-110-2-G

Obligation d'aller à gauche

300 x 300 mm  
450 x 450 mm  
600 x 600 mm  
750 x 750 mm  
900 x 900 mm



P-110-3-G

Obligation tout droit ou gauche

300 x 300 mm  
450 x 450 mm  
600 x 600 mm  
750 x 750 mm  
900 x 900 mm



P-110-3-D

Obligation tout droit ou droite

300 x 300 mm  
450 x 450 mm  
600 x 600 mm  
750 x 750 mm  
900 x 900 mm



P-110-4

Obligation gauche ou droite

300 x 300 mm  
450 x 450 mm  
600 x 600 mm  
750 x 750 mm  
900 x 900 mm



P-110-5

Interdit de faire demi-tour

300 x 300 mm  
450 x 450 mm  
600 x 600 mm  
750 x 750 mm  
900 x 900 mm  
1200 x 1200 mm



P-110-6

Interdit de tourner à gauche

300 x 300 mm  
450 x 450 mm  
600 x 600 mm  
750 x 750 mm  
900 x 900 mm  
1200 x 1200 mm



P-110-7

Interdit de tourner à droite

300 x 300 mm  
450 x 450 mm  
600 x 600 mm  
750 x 750 mm  
900 x 900 mm  
1200 x 1200 mm



P-110-8

Interdit d'aller tout droit

300 x 300 mm  
450 x 450 mm  
600 x 600 mm  
750 x 750 mm  
900 x 900 mm



P-110-P-1

Heures et jours

300 x 150 mm  
600 x 300 mm  
750 x 380 mm  
900 x 450 mm



<b>P-110-P-2</b> <i>Excepté véhicules autorisés</i>	<b>P-110-P-3</b> <i>Heures et jours excepté taxis</i>	<b>P-110-P-4</b> <i>Excepté autobus</i>	<b>P-110-P-5</b> <i>Excepté bicyclettes</i>	<b>P-115-1</b> <i>Vir. à droite interdit feu rouge</i>	<b>P-115-3</b> <i>Vir. à droite interdit feu rouge</i>
300 x 230 mm	600 x 450 mm	600 x 300 mm	600 x 300 mm	600 x 900 mm	600 x 1200 mm
450 x 300 mm	900 x 600 mm	750 x 380 mm	750 x 380 mm		
600 x 450 mm		900 x 450 mm	900 x 450 mm		
900 x 600 mm					
1200 x 900 mm					



<b>P-120-1</b> <i>Trajet oblig. camions</i>	<b>P-120-2</b> <i>Trajet oblig. automobiles</i>	<b>P-120-3</b> <i>Trajet oblig. motocyclettes</i>	<b>P-120-4</b> <i>Trajet oblig. trans. mat. dangereuse</i>	<b>P-120-5</b> <i>Oblig. circuler dans cette voie</i>	<b>P-120-6</b> <i>Oblig. circuler dans cette voie</i>
600 x 600 mm	600 x 600 mm	600 x 600 mm	600 x 600 mm	900 x 1200 mm	900 x 1200 mm
900 x 900 mm	900 x 900 mm	900 x 900 mm	900 x 900 mm	1200 x 1800 mm	1200 x 1800 mm
1200 x 1200 mm	1200 x 1200 mm	1200 x 1200 mm	1200 x 1200 mm		



<b>P-120-7</b> <i>Trajet oblig. motoneiges</i>	<b>P-120-8</b> <i>Trajet oblig. quads</i>	<b>P-120-9</b> <i>Trajet oblig. cyclistes</i>	<b>P-120-12</b> <i>Trajet oblig. pour camions</i>	<b>P-120-12-D</b> <i>Trajet oblig. pour camions</i>	<b>P-120-12-G</b> <i>Trajet oblig. pour camions</i>
300 x 300 mm	300 x 300 mm	300 x 300 mm	600 x 750 mm	600 x 750 mm	600 x 750 mm
600 x 600 mm	600 x 600 mm	600 x 600 mm	900 x 1200 mm	900 x 1200 mm	900 x 1200 mm
900 x 900 mm	900 x 900 mm	900 x 900 mm	1200 x 1800 mm	1200 x 1800 mm	1200 x 1800 mm
1200 x 1200 mm	1200 x 1200 mm	1200 x 1200 mm			



<b>P-120-12-G-D</b> <i>Trajet oblig. pour camions</i>	<b>P-120-13-D</b> <i>Trajet oblig. pour camions</i>	<b>P-120-13-G</b> <i>Trajet oblig. pour camions</i>	<b>P-120-14-D</b> <i>Trajet oblig. pour camions</i>	<b>P-120-14-G</b> <i>Trajet oblig. pour camions</i>	<b>P-130-1</b> <i>Accès interdit aux camions</i>
600 x 750 mm	600 x 750 mm	600 x 750 mm	600 x 750 mm	600 x 750 mm	600 x 600 mm
900 x 1200 mm	900 x 1200 mm	900 x 1200 mm	900 x 1200 mm	900 x 1200 mm	750 x 750 mm
1200 x 1800 mm	1200 x 1800 mm	1200 x 1800 mm	1200 x 1800 mm	1200 x 1800 mm	900 x 900 mm
					1200 x 1200 mm



<b>P-130-P-1</b> <i>Excepté livraison locale</i>	<b>P-130-P-2</b> <i>Excepté fast express</i>	<b>P-130-2</b> <i>Voie interdite aux camions</i>	<b>P-130-3</b> <i>Accès interdit</i>	<b>P-130-4</b> <i>Accès interdit</i>	<b>P-130-5</b> <i>Accès interdit</i>
600 x 450 mm	1200 x 600 mm	1200 x 1800 mm	600 x 600 mm	300 x 300 mm	300 x 300 mm
900 x 600 mm		1500 x 2400 mm	900 x 900 mm	450 x 450 mm	450 x 450 mm
1200 x 900 mm		2000 x 2745 mm	1200 x 1200 mm	600 x 600 mm	600 x 600 mm
				900 x 900 mm	
				1200 x 1200 mm	



P-130-6

P-130-7

P-130-8

P-130-9

P-130-10

P-130-11

Accès interdit

Accès interdit

Accès interdit

Accès interdit

Accès interdit

Accès interdit

300 x 300 mm  
450 x 450 mm  
600 x 600 mm  
900 x 900 mm

300 x 300 mm  
450 x 450 mm  
600 x 600 mm

300 x 300 mm  
450 x 450 mm  
600 x 600 mm  
1200 x 1200 mm

600 x 600 mm

450 x 450 mm  
600 x 600 mm

300 x 300 mm  
450 x 450 mm  
600 x 600 mm  
900 x 900 mm



P-130-12

P-130-13

P-130-14

P-130-15

P-130-16

P-130-17

Accès interdit

Accès interdit

Accès interdit

Accès interdit aux camions

Accès interdit aux camions

Accès interdit aux camions

300 x 300 mm  
450 x 450 mm  
600 x 600 mm  
900 x 900 mm

300 x 300 mm  
450 x 450 mm  
600 x 600 mm  
900 x 900 mm  
1200 x 1200 mm

300 x 300 mm  
450 x 450 mm  
600 x 600 mm  
900 x 900 mm  
1200 x 1200 mm

900 x 1200 mm

900 x 1200 mm

900 x 900 mm  
1200 x 1200 mm



P-130-18

P-130-19

P-130-20

P-130-21

P-130-22

P-130-23

Accès interdit aux camions

Accès interdit aux camions

Accès interdit aux camions

Accès interdit

Accès interdit

Accès interdit

900 x 900 mm  
1200 x 1200 mm

900 x 1200 mm

600 x 750 mm  
900 x 1200 mm  
1200 x 1800 mm

600 x 600 mm

600 x 600 mm

600 x 600 mm



P-130-24

P-130-25

P-130-26

P-130-27

P-130-28

P-130-29

Livraison locale seulement

Accès interdit aux camions

Accès interdit aux camions

Accès interdit aux camions

Accès interdit

Accès interdit

600 x 750 mm  
900 x 1200 mm

900 x 900 mm  
1200 x 1200 mm

600 x 750 mm  
900 x 1200 mm

900 x 900 mm  
1200 x 1200 mm

600 x 600 mm  
900 x 900 mm  
1200 x 1200 mm

600 x 600 mm  
900 x 900 mm  
1200 x 1200 mm



P-130-30

P-130-33

P-130-34

P-130-35

P-130-37-D

P-130-37-G

Accès interdit

Voie interdite

Accès interdit

Accès interdit

Accès interdit aux camions

Accès interdit aux camions

600 x 600 mm  
900 x 900 mm  
1200 x 1200 mm

900 x 1200 mm  
1200 x 1800 mm

600 x 600 mm

600 x 600 mm

1200 x 1800 mm

1200 x 1800 mm



<b>P-130-48</b> Accès interdit aux camions 4000 x 2440 mm	<b>P-130-49</b> Accès interdit aux camions 4000 x 2440 mm	<b>P-130-50</b> Accès interdit aux camions 2500 x 3965 mm	<b>P-130-51</b> Accès interdit aux camions 2500 x 3965 mm	<b>P-130-52</b> Accès interdit aux camions 4000 x 3660 mm	<b>P-130-53</b> Accès interdit aux camions 4000 x 3660 mm
---	---	---	---	---	---



<b>P-130-57</b> Accès int. véhicules basse vitesse 600 x 600 mm 900 x 900 mm 1200 x 1200 mm	<b>P-130-59</b> Accès interdit 600 x 600 mm 900 x 900 mm 1200 x 1200 mm	<b>P-130-62</b> Accès interdit 600 x 600 mm 900 x 900 mm 1200 x 1200 mm	<b>P-140-1</b> Interdiction de dépasser 600 x 600 mm 750 x 750 mm 900 x 900 mm 1200 x 1200 mm	<b>P-150-1</b> Stationnement réglementé 300 x 300 mm 450 x 450 mm 600 x 600 mm 900 x 900 mm	<b>P-150-1-D</b> Stationnement réglementé 600 x 600 mm 900 x 900 mm
---	---	---	--	--	--



<b>P-150-1-G</b> Stationnement réglementé 600 x 600 mm 900 x 900 mm	<b>P-150-1-G-D</b> Stationnement réglementé 600 x 600 mm 900 x 900 mm	<b>P-150-2</b> Stationnement réglementé 300 x 450 mm 300 x 600 mm 300 x 750 mm	<b>P-150-2-D</b> Stationnement réglementé 300 x 450 mm 300 x 600 mm 300 x 750 mm	<b>P-150-2-G</b> Stationnement réglementé 300 x 450 mm 300 x 600 mm 300 x 750 mm	<b>P-150-2-G-D</b> Stationnement réglementé 300 x 450 mm 300 x 600 mm 300 x 750 mm
--	--	--	--	--	--

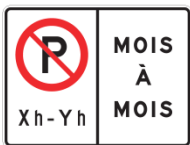

<b>P-150-4</b> Stationnement réglementé 1200 x 900 mm 1800 x 1200 mm	<b>P-150-5</b> Stationnement réglementé 300 x 600 mm	<b>P-150-5-D</b> Stationnement réglementé 300 x 600 mm	<b>P-150-5-G</b> Stationnement réglementé 300 x 600 mm	<b>P-150-5-G-D</b> Stationnement réglementé 300 x 600 mm	<b>P-150-7</b> Stationnement autorisé 300 x 450 mm 300 x 600 mm 300 x 750 mm
---	--	--	--	--	--



<b>P-150-7-D</b> Stationnement autorisé 300 x 450 mm 300 x 600 mm 300 x 750 mm	<b>P-150-7-G</b> Stationnement autorisé 300 x 450 mm 300 x 600 mm 300 x 750 mm	<b>P-150-7-G-D</b> Stationnement autorisé 300 x 450 mm 300 x 600 mm 300 x 750 mm	<b>P-150-8</b> Stationnement réglementé 300 x 600 mm	<b>P-150-9</b> Stationnement réglementé 300 x 450 mm 300 x 600 mm 300 x 750 mm	<b>P-150-10</b> Stationnement réglementé 300 x 600 mm
--	--	--	--	--	---



**P-150-10-D**  
Stationnement réglementé  
300 x 600 mm

**P-150-10-G**  
Stationnement réglementé  
300 x 600 mm

**P-150-10-G-D**  
Stationnement réglementé  
300 x 600 mm

**P-150-P-1**  
Remorquage  
300 x 150 mm

**P-150-P-2-D**  
Horodateur  
300 x 150 mm

**P-150-P-2-G**  
Horodateur  
300 x 150 mm



**P-150-P-3**  
Municipalité  
1200 x 300 mm

**P-150-P-4**  
Stationnement réglementé  
300 x 150 mm

**P-150-P-5**  
Stationnement réglementé  
300 x 150 mm

**P-160-1**  
Arrêt interdit  
300 x 450 mm  
300 x 750 mm

**P-160-1-D**  
Arrêt interdit  
300 x 450 mm  
300 x 600 mm  
300 x 750 mm

**P-160-1-G**  
Arrêt interdit  
300 x 450 mm  
300 x 600 mm  
300 x 750 mm



**P-160-1-G-D**  
Arrêt interdit  
300 x 450 mm  
300 x 600 mm  
300 x 750 mm

**P-160-3**  
Arrêt interdit  
600 x 600 mm  
900 x 900 mm

**P-160-3-D**  
Arrêt interdit  
600 x 600 mm  
900 x 900 mm

**P-160-3-G**  
Arrêt interdit  
600 x 600 mm  
900 x 900 mm

**P-160-3-G-D**  
Arrêt interdit  
600 x 600 mm  
900 x 900 mm

**P-170-1**  
Arrêt interdit sur voie ferrée  
600 x 750 mm  
900 x 1200 mm



**P-170-2**  
Arrêt interdit sur voie ferrée  
600 x 750 mm  
900 x 1200 mm

**P-170-3**  
Arrêt interdit sur voie ferrée  
600 x 750 mm  
900 x 1200 mm

**P-180-1**  
Exemption d'arrêt sur voie ferrée  
900 x 1200 mm  
1200 x 1800 mm

**P-180-2**  
Exemption d'arrêt sur voie ferrée  
900 x 1200 mm  
1200 x 1800 mm

**P-180-3**  
Exemption d'arrêt sur voie ferrée  
900 x 1200 mm  
1200 x 1800 mm

**P-195**  
Limitation de poids  
600 x 750 mm

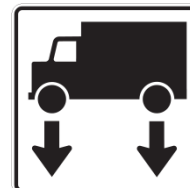

**P-200-1**  
Limitation de poids  
600 x 750 mm  
900 x 1200 mm

**P-200-2**  
Limitation de poids  
600 x 600 mm  
750 x 750 mm  
900 x 900 mm  
1200 x 1200 mm

**P-200-3**  
Limitation de poids  
600 x 600 mm  
750 x 750 mm  
900 x 900 mm  
1200 x 1200 mm

**P-200-P-1**  
Un véhicule à la fois  
600 x 300 mm  
900 x 450 mm  
1200 x 600 mm

**P-210**  
Dégel  
300 x 300 mm  
600 x 600 mm  
900 x 900 mm  
1200 x 1200 mm

**P-220**  
Voie pour véhicule lent  
600 x 750 mm

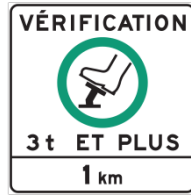

P-225	P-230-P	P-231-1	P-231-2	P-231-3	P-240-1
Trajet oblig. voie de dépassement	Fin	Vérification des freins	Vérification des freins	Vérification des freins	Postes et aires de ctrl routier
600 x 900 mm	300 x 150 mm	3000 x 3050 mm	1200 x 1200 mm	4000 x 2440 mm	600 x 750 mm
900 x 1200 mm	450 x 225 mm			5000 x 3050 mm	900 x 1200 mm
1200 x 1800 mm	600 x 300 mm				
	900 x 450 mm				
	1200 x 600 mm				



P-240-2	P-240-3	P-240-4	P-240-5	P-240-P-1	P-240-P-2-D
Postes et aires de ctrl routier	Postes et aires de ctrl routier	Postes et aires de ctrl routier	Postes et aires de ctrl routier	Direction	Direction
2400 x 1800 mm	1800 x 900 mm	600 x 750 mm		300 x 150 mm	300 x 150 mm
3500 x 2745 mm		900 x 1200 mm		450 x 225 mm	450 x 225 mm
				600 x 300 mm	600 x 300 mm
				750 x 375 mm	900 x 450 mm
				900 x 450 mm	1200 x 600 mm
				1200 x 600 mm	



P-240-P-2-G	P-240-P-3	P-240-P-3-G-D	P-240-P-4-D	P-240-P-4-G	P-240-P-5-D
Direction	Direction	Direction	Direction	Direction	Direction
300 x 150 mm	300 x 150 mm	300 x 150 mm	300 x 150 mm	300 x 150 mm	300 x 150 mm
450 x 225 mm	450 x 225 mm	450 x 225 mm	450 x 225 mm	450 x 225 mm	450 x 225 mm
600 x 300 mm	600 x 300 mm	600 x 300 mm	600 x 300 mm	600 x 300 mm	600 x 300 mm
900 x 450 mm	900 x 450 mm	900 x 450 mm	900 x 450 mm	900 x 450 mm	900 x 450 mm
1200 x 600 mm	1200 x 600 mm	1200 x 600 mm	1200 x 600 mm	1200 x 600 mm	1200 x 600 mm



P-240-P-5-G	P-240-P-6	P-240-P-7-D	P-240-P-7-G	P-240-P-8-D	P-240-P-8-G
Direction	Direction et distance	Direction et distance	Direction et distance	Direction et distance	Direction et distance
300 x 150 mm	600 x 300 mm	750 x 380 mm	750 x 380 mm	750 x 375 mm	750 x 375 mm
450 x 225 mm	750 x 375 mm	900 x 450 mm	900 x 450 mm	900 x 450 mm	900 x 450 mm
600 x 300 mm	900 x 450 mm	1200 x 600 mm	1200 x 600 mm	1200 x 600 mm	1200 x 600 mm
900 x 450 mm	1200 x 600 mm				
1200 x 600 mm					



P-240-P-9-D	P-240-P-9-G	P-240-P-10-D	P-240-P-10-G	P-240-P-11	P-240-P-12-D
Direction	Direction	Direction et distance	Direction et distance	Direction et distance	Direction et distance
300 x 150 mm	300 x 150 mm	600 x 300 mm	600 x 300 mm	600 x 300 mm	600 x 300 mm
450 x 225 mm	450 x 225 mm	750 x 375 mm	750 x 375 mm	750 x 375 mm	750 x 375 mm
600 x 300 mm	600 x 300 mm	900 x 450 mm	900 x 450 mm	900 x 450 mm	900 x 450 mm
750 x 375 mm	750 x 375 mm	1200 x 600 mm	1200 x 600 mm	1200 x 600 mm	1200 x 600 mm
900 x 450 mm	900 x 450 mm				
1200 x 600 mm	1200 x 600 mm				





P-240-P-12-G	P-245-P-2	P-245-P-3	P-245-P-4	P-250-1	P-250-2
Direction et distance	Distance	Distance	Distance	Voies réservées	Voies réservées
600 x 300 mm	600 x 300 mm	600 x 300 mm	600 x 300 mm	600 x 750 mm	600 x 750 mm
750 x 375 mm	750 x 380 mm	750 x 380 mm	750 x 380 mm	900 x 1200 mm	900 x 1200 mm
900 x 450 mm	900 x 450 mm	900 x 450 mm	900 x 450 mm		
1200 x 600 mm	1200 x 600 mm	1200 x 600 mm	1200 x 600 mm		

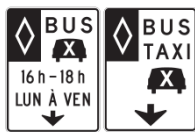

P-250-3	P-250-4	P-250-5	P-250-6	P-250-7	P-250-P-2
Voies réservées : fin	Voies réservées	Voies réservées	Voies réservées : fin	Voies réservées	Étendue
600 x 750 mm	600 x 750 mm	600 x 600 mm	600 x 600 mm	900 x 1350 mm	600 x 300 mm
900 x 1200 mm	900 x 1200 mm	900 x 900 mm	900 x 900 mm	2000 x 3050 mm	900 x 450 mm
2000 x 2745 mm		1200 x 1200 mm			1200 x 600 mm



P-250-P-3	P-270-1-A	P-270-1-D	P-270-1-G	P-270-2-A	P-270-2-D
Étendue	Passage pour écoliers	Passage pour écoliers	Passage pour écoliers	Passage pour piétons	Passage pour piétons
600 x 300 mm	900 x 1200 mm	600 x 750 mm	600 x 750 mm	900 x 1200 mm	600 x 750 mm
900 x 450 mm		900 x 1200 mm	900 x 1200 mm		900 x 1200 mm
1200 x 600 mm					



P-270-2-G	P-270-3-A	P-270-3-D	P-270-3-G	P-270-4-A	P-270-4-D
Passage pour piétons	Passage pour enfants	Passage pour enfants	Passage pour enfants	Passage pour déficients physiques	Passage pour déficients physiques
600 x 750 mm	600 x 750 mm	600 x 750 mm	600 x 750 mm	600 x 750 mm	600 x 750 mm
900 x 1200 mm	900 x 1200 mm	900 x 1200 mm	900 x 1200 mm	900 x 1200 mm	900 x 1200 mm



P-270-4-G	P-270-5-A	P-270-5-D	P-270-5-G	P-270-6-A	P-270-6-D
Passage pour déficients physiques	Passage pour déficients visuels	Passage pour déficients visuels	Passage pour déficients visuels	Passage pour piétons et cyclistes	Passage pour piétons et cyclistes
600 x 750 mm	600 x 750 mm	600 x 750 mm	600 x 750 mm	600 x 750 mm	600 x 750 mm
900 x 1200 mm	900 x 1200 mm	900 x 1200 mm	900 x 1200 mm	900 x 1200 mm	900 x 1200 mm



**P-270-6-G**

*Passage pour piétons et cyclistes*

600 x 750 mm  
900 x 1200 mm

**P-300**

*Port oblig. ceinture de sécurité*

900 x 900 mm  
1200 x 1200 mm  
1800 x 1800 mm

**P-310**

*Défense de jeter des ordures*

300 x 300 mm  
450 x 450 mm  
600 x 600 mm  
900 x 900 mm

**P-315**

*Eau non potable*

150 x 150 mm  
300 x 300 mm  
450 x 450 mm  
600 x 600 mm

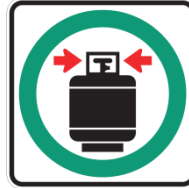

**P-320**

*Détecteurs de radar interdits*

1500 x 1200 mm  
2400 x 1500 mm

**P-330**

*Limiteur de vitesse*

2400 x 1800 mm  
3500 x 2745 mm  
5000 x 3660 mm

**P-340**

*Fermer et sceller bonbonnes de gaz*

600 x 600 mm  
750 x 750 mm  
900 x 900 mm  
1200 x 1200 mm

**P-340-P**

*Fermez et scellez*

600 x 300 mm  
750 x 380 mm  
900 x 450 mm  
1200 x 600 mm



**P-135**

*Interdiction d'utiliser le frein moteur*

600 x 900 mm  
900 x 1350 mm  
1200 x 1800 mm

# PANNEAUX SPÉCIAUX

					
PS-101 Stationnement réservé 300 x 450 mm	PS-102 Stationnement réservé 300 x 450 mm	PS-104 Stationnement réservé 300 x 450 mm	PS-105 Attention à nos enfants 600 x 600 mm	AAE Attention à nos enfants 600 x 600 mm	RAE Attention à nos enfants 600 x 600 mm
					
D-70-J Attention à nos enfants 600 x 600 mm	RH-25-E Stationnement réservé 300 x 450 mm	FM-105 Freins moteurs 600 x 750 mm	FM-106 Freins moteurs 600 x 600 mm	PS-107 Présence de malentendants 600 x 600 mm	PS-108 Déneigement 600 x 600 mm
					
PS-109 Lentement niveleuse 600 x 600 mm	BFS Borne sèche 300 x 450 mm	RVB Repère de valve 300 x 300 mm	RBS Borne siamoise Diamètre 300 mm	PS-110 Permis municipal obligatoire 600 x 300 mm	PS-111 Surveillance par caméra 450 x 600 mm
					
PS-113-1 ou PS-141 Point de rassemblement 600 x 600 mm	PS-113-2 ou PS-140 Point de rassemblement 600 x 600 mm	P-130-106 Interdiction aux chiens 600 x 600 mm	P-120-102 Oblig. ramasser les besoins 600 x 600 mm	P-120-100 Laisse obligatoire 600 x 600 mm	PS-115 Glace mince 600 x 600 mm
					
P-150-P-1-1 Remorquage à vos frais 300 x 450 mm	AIR-COMP Air comprimé 300 x 450 mm	PTN Plantation 300 x 300 mm	CAM-1 Caméra 300 x 450 mm	CAM-2 Caméra 300 x 450 mm	CAM-3 Caméra 600 x 600 mm
					
P-VAA Virée autobus 300 x 450 mm	P-150-R Stationnement reculons 200 x 350 mm	Z-VILL Zone de villégiature 300 x 450 mm	P-HOM Utiliser porte d'homme 300 x 450 mm	CH-NEI Danger chute de neige 300 x 450 mm	HT-LIB Hauteur libre 36 x 6'

# PANNEAU DE CAMÉRA

*avec texte personnalisable*



Couleur  
du texte

NOIR

ROUGE

**Dimensions  
rectangulaires**  
mm

150 x 300  
300 x 450  
300 x 600  
600 x 750  
600 x 900  
600 x 1200  
900 x 1200

**Dimensions  
carrés**  
mm

150 x 150  
300 x 300  
450 x 450  
600 x 600  
750 x 750  
900 x 900  
1200 x 1200

1

2

3

4





5

6



## FORMES ET COULEURS DES PANNEAUX

selon les normes du Ministère des Transports du Québec

Forme	Couleur	Description
	Jaune	Réservé aux danger
	Jaune	Danger
	Jaune	Danger
	Chartreuse	Réservé à la zone scolaire



STOP  
ENLEVÉ  
DATE

ARRÊT  
ENLEVÉ  
DATE

ARRÊT  
EN VIGUEUR  
DATE

STOP  
EN VIGUEUR  
DATE

D-010-1	D-010-1-S	D-020	D-030	D-040-1	D-040-2
Signal avancé d'arrêt	Signal avancé de stop	Signal avancé de cédez	Signal avancé de cédez	Nouvelle signalisation	Nouvelle signalisation
450 x 450 mm	450 x 450 mm	450 x 450 mm	450 x 450 mm	450 x 450 mm	450 x 450 mm
600 x 600 mm	600 x 600 mm	600 x 600 mm	600 x 600 mm	600 x 600 mm	600 x 600 mm
750 x 750 mm	750 x 750 mm	750 x 750 mm	750 x 750 mm	750 x 750 mm	750 x 750 mm
900 x 900 mm	900 x 900 mm	900 x 900 mm	900 x 900 mm	900 x 900 mm	900 x 900 mm
1200 x 1200 mm	1200 x 1200 mm	1200 x 1200 mm	1200 x 1200 mm	1200 x 1200 mm	1200 x 1200 mm



FEUX  
ENLEVÉS  
DATE

FEUX  
EN SERVICE  
DATE

VITESSE  
XX km/h  
EN VIGUEUR  
DATE

D-040-3	D-040-4	D-040-5	D-040-6	D-040-7	D-040-8
Nouvelle signalisation	Nouvelle signalisation	Nouvelle signalisation	Nouvelle signalisation	Nouvelle signalisation	Nouvelle signalisation
450 x 450 mm	450 x 450 mm	450 x 450 mm	450 x 450 mm	450 x 450 mm	450 x 450 mm
600 x 600 mm	600 x 600 mm	600 x 600 mm	600 x 600 mm	600 x 600 mm	600 x 600 mm
750 x 750 mm	750 x 750 mm	750 x 750 mm	750 x 750 mm	750 x 750 mm	750 x 750 mm
900 x 900 mm	900 x 900 mm	900 x 900 mm	900 x 900 mm	900 x 900 mm	900 x 900 mm
1200 x 1200 mm	1200 x 1200 mm	1200 x 1200 mm	1200 x 1200 mm	1200 x 1200 mm	1200 x 1200 mm

NOUVELLE  
SIGNALISATION

NOUVELLE  
VITESSE



D-040-P-1	D-040-P-2	D-050-1	D-060-1	D-060-2	D-060-3
Nouvelle signalisation	Nouvelle vitesse	Signal avancé de feux	Préparez-vous à arrêter	Préparez-vous à arrêter	Signal avancé passage camion
600 x 300 mm	600 x 300 mm	450 x 450 mm	1800 x 1500 mm	1800 x 1500 mm	1800 x 1200 mm
750 x 375 mm	750 x 375 mm	600 x 600 mm	2400 x 2100 mm	2400 x 2100 mm	2400 x 1500 mm
900 x 450 mm	900 x 450 mm	750 x 750 mm	3500 x 3050 mm	3500 x 3050 mm	3000 x 2135 mm
1200 x 600 mm	1200 x 600 mm	900 x 900 mm			
		1200 x 1200 mm			



PRÉPAREZ-VOUS  
À ARRÊTER



D-060-4	D-060-P	D-070	D-070-30	D-070-40	D-070-50
Préparez-vous à arrêter	Préparez-vous à arrêter	Signal avancé limite vitesse	Signal avancé limite vitesse	Signal avancé limite vitesse	Signal avancé limite vitesse
1800 x 1500 mm	1800 x 450 mm	450 x 450 mm	450 x 450 mm	450 x 450 mm	450 x 450 mm
2400 x 2100 mm	2400 x 600 mm	600 x 600 mm	600 x 600 mm	600 x 600 mm	600 x 600 mm
3500 x 3050 mm	3500 x 915 mm	750 x 750 mm	750 x 750 mm	750 x 750 mm	750 x 750 mm
		900 x 900 mm	900 x 900 mm	900 x 900 mm	900 x 900 mm
		1200 x 1200 mm	1200 x 1200 mm	1200 x 1200 mm	1200 x 1200 mm



Xh-Yh  
JOUR À JOUR  
MOIS À MOIS



D-070-70	D-070-P	D-080	D-090-1	D-090-2	D-090-2
Signal avancé limite vitesse	Durée de la période	Signal avancé circ. deux sens	Début chaussée séparée	Fin chaussée séparée	Chaussée séparée deux côtés
450 x 450 mm	600 x 450 mm	450 x 450 mm	450 x 450 mm	450 x 450 mm	450 x 450 mm
600 x 600 mm	750 x 500 mm	600 x 600 mm	600 x 600 mm	600 x 600 mm	600 x 600 mm
750 x 750 mm	900 x 600 mm	750 x 750 mm	750 x 750 mm	750 x 750 mm	750 x 750 mm
900 x 900 mm	1200 x 900 mm	900 x 900 mm	900 x 900 mm	900 x 900 mm	900 x 900 mm
1200 x 1200 mm		1200 x 1200 mm	1200 x 1200 mm	1200 x 1200 mm	1200 x 1200 mm



VOIE DE GAUCHE

VOIE DE DROITE



VOIE DU CENTRE

D-100-2-D	D-100-2-G	D-100-2-P-1	D-100-2-P-2	D-100-5	D-100-2-P-2
Signal avancé dir. des voies	Signal avancé dir. des voies	Voie de gauche	Voie de droite	Signal avancé dir. des voies	Voie du centre
600 x 600 mm	600 x 600 mm	300 x 600 mm	300 x 600 mm	600 x 600 mm	300 x 600 mm
750 x 750 mm	750 x 750 mm	750 x 380 mm	750 x 380 mm	750 x 750 mm	750 x 380 mm
900 x 900 mm	900 x 900 mm	900 x 450 mm	900 x 450 mm	900 x 900 mm	900 x 450 mm
1200 x 1200 mm	1200 x 1200 mm	1200 x 600 mm	1200 x 600 mm	1200 x 1200 mm	1200 x 600 mm



D-100-6-D	D-100-6-G	D-100-6-G-D	D-100-7-D	D-100-7-G	D-100-8-A
Signal avancé dir. des voies	Signal avancé dir. des voies	Signal avancé dir. des voies	Signal avancé dir. des voies	Signal avancé dir. des voies	Signal avancé dir. des voies
600 x 600 mm	600 x 600 mm	600 x 600 mm	600 x 600 mm	600 x 600 mm	600 x 600 mm
750 x 750 mm	750 x 750 mm	750 x 750 mm	750 x 750 mm	750 x 750 mm	750 x 750 mm
900 x 900 mm	900 x 900 mm	900 x 900 mm	900 x 900 mm	900 x 900 mm	900 x 900 mm
1200 x 1200 mm	1200 x 1200 mm	1200 x 1200 mm			1200 x 1200 mm



D-100-8-B	D-100-8-C	D-100-8-D	D-100-8-E	D-100-8-F	D-100-8-G
Signal avancé dir. des voies	Signal avancé dir. des voies	Signal avancé dir. des voies	Signal avancé dir. des voies	Signal avancé dir. des voies	Signal avancé dir. des voies
600 x 600 mm	600 x 600 mm	600 x 600 mm	600 x 600 mm	600 x 600 mm	600 x 600 mm
750 x 750 mm	750 x 750 mm	750 x 750 mm	750 x 750 mm	750 x 750 mm	750 x 750 mm
900 x 900 mm	900 x 900 mm	900 x 900 mm	900 x 900 mm	900 x 900 mm	900 x 900 mm
1200 x 1200 mm	1200 x 1200 mm	1200 x 1200 mm	1200 x 1200 mm	1200 x 1200 mm	1200 x 1200 mm



D-100-8-I	D-100-8-J	D-100-9-D	D-100-9-G	D-100-9-G-D	D-100-10-D
Signal avancé dir. des voies	Signal avancé dir. des voies	Signal avancé dir. des voies	Signal avancé dir. des voies	Signal avancé dir. des voies	Signal avancé dir. des voies
600 x 600 mm	600 x 600 mm	600 x 600 mm	600 x 600 mm	600 x 600 mm	600 x 600 mm
750 x 750 mm	750 x 750 mm	750 x 750 mm	750 x 750 mm	750 x 750 mm	750 x 750 mm
900 x 900 mm	900 x 900 mm	900 x 900 mm	900 x 900 mm	900 x 900 mm	900 x 900 mm
1200 x 1200 mm	1200 x 1200 mm	1200 x 1200 mm	1200 x 1200 mm	1200 x 1200 mm	1200 x 1200 mm



VOIES DE GAUCHE

VOIES DE DROITE



D-100-10-G	D-100-11-D	D-100-11-G	D-100-11-P-1	D-100-11-P-2	D-100-12-D
Signal avancé dir. des voies	Signal avancé dir. des voies	Signal avancé dir. des voies	Voies de gauche	Voies de droite	Signal avancé dir. des voies
600 x 600 mm	600 x 600 mm	600 x 600 mm	300 x 600 mm	300 x 600 mm	600 x 600 mm
750 x 750 mm	750 x 750 mm	750 x 750 mm	750 x 380 mm	750 x 380 mm	750 x 750 mm
900 x 900 mm	900 x 900 mm	900 x 900 mm	900 x 450 mm	900 x 450 mm	900 x 900 mm
1200 x 1200 mm	1200 x 1200 mm	1200 x 1200 mm	1200 x 600 mm	1200 x 600 mm	





D-100-12-G	D-110-1-D	D-110-1-G	D-110-2-D	D-110-2-G	D-110-3-D
Signal avancé dir. des voies	Virage à droite	Virage à gauche	Virage à droite	Virage à gauche	Virage double
600 x 600 mm	300 x 300 mm	300 x 300 mm	300 x 300 mm	300 x 300 mm	300 x 300 mm
750 x 750 mm	450 x 450 mm	450 x 450 mm	450 x 450 mm	450 x 450 mm	600 x 600 mm
900 x 900 mm	600 x 600 mm	600 x 600 mm	600 x 600 mm	600 x 600 mm	750 x 750 mm
	750 x 750 mm	750 x 750 mm	750 x 750 mm	750 x 750 mm	900 x 900 mm
	900 x 900 mm	900 x 900 mm	900 x 900 mm	900 x 900 mm	1200 x 1200 mm
	1200 x 1200 mm	1200 x 1200 mm	1200 x 1200 mm	1200 x 1200 mm	



D-110-3-G	D-110-4-D	D-110-4-G	D-110-5-D	D-110-5-G	D-110-6-D
Virage double	Virage double	Virage double	Virage triple	Virage triple	Virage à droite 180°
300 x 300 mm	300 x 300 mm	300 x 300 mm	300 x 300 mm	300 x 300 mm	300 x 300 mm
600 x 600 mm	600 x 600 mm	600 x 600 mm	600 x 600 mm	600 x 600 mm	750 x 750 mm
750 x 750 mm	750 x 750 mm	750 x 750 mm	750 x 750 mm	750 x 750 mm	900 x 900 mm
900 x 900 mm	900 x 900 mm	900 x 900 mm	900 x 900 mm	900 x 900 mm	1200 x 1200 mm
1200 x 1200 mm	1200 x 1200 mm	1200 x 1200 mm	1200 x 1200 mm	1200 x 1200 mm	



D-110-6-G	D-110-7-D	D-110-7-G	D-110-P-2	D-110-P-2-15	D-110-P-2-25
Virage à gauche 180°	Renversement de camion	Renversement de camion	Vitesse recommandée	Vitesse recommandée	Vitesse recommandée
300 x 300 mm	1500 x 2400 mm	1500 x 2400 mm	450 x 450 mm	450 x 450 mm	450 x 450 mm
600 x 600 mm			600 x 600 mm	600 x 600 mm	600 x 600 mm
750 x 750 mm			750 x 750 mm	750 x 750 mm	750 x 750 mm
900 x 900 mm			900 x 900 mm	900 x 900 mm	900 x 900 mm
1200 x 1200 mm					



D-110-P-2-35	D-110-P-2-45	D-110-P-2-55	D-110-P-2-65	D-110-P-2-75	D-110-P-2-85
Vitesse recommandée	Vitesse recommandée	Vitesse recommandée	Vitesse recommandée	Vitesse recommandée	Vitesse recommandée
450 x 450 mm	450 x 450 mm	450 x 450 mm	450 x 450 mm	450 x 450 mm	450 x 450 mm
600 x 600 mm	600 x 600 mm	600 x 600 mm	600 x 600 mm	600 x 600 mm	600 x 600 mm
750 x 750 mm	750 x 750 mm	750 x 750 mm	750 x 750 mm	750 x 750 mm	750 x 750 mm
900 x 900 mm	900 x 900 mm	900 x 900 mm	900 x 900 mm	900 x 900 mm	900 x 900 mm



D-120	D-120-15	D-120-25	D-120-45	D-120-55	D-120-65
Vitesse recommandée	Vitesse recommandée	Vitesse recommandée	Vitesse recommandée	Vitesse recommandée	Vitesse recommandée
900 x 1200 mm	900 x 1200 mm	900 x 1200 mm	900 x 1200 mm	900 x 1200 mm	900 x 1200 mm



D-120-75	D-120-85	D-130-1-D	D-130-1-G	D-130-2-G-D	D-140-1-D
Vitesse recommandée	Vitesse recommandée	Flèche directionnelle	Flèche directionnelle	Flèche directionnelle	Voies convergentes droite
900 x 1200 mm	900 x 1200 mm	300 x 300 mm	300 x 300 mm	300 x 300 mm	1200 x 1200 mm
		450 x 450 mm	450 x 450 mm	450 x 450 mm	
		600 x 600 mm	600 x 600 mm	600 x 600 mm	
		750 x 750 mm	750 x 750 mm	750 x 750 mm	
		900 x 900 mm	900 x 900 mm	900 x 900 mm	
		1200 x 1200 mm	1200 x 1200 mm	1200 x 1200 mm	



D-140-1-G	D-140-2-D	D-140-2-G	D-140-3	D-150-D	D-150-G
Voies convergentes gauche	Voies parallèles entrée droite	Voies parallèles entrée gauche	Routes convergentes	Voies convergentes d'autobus	Voies convergentes d'autobus
1200 x 1200 mm	1200 x 1200 mm	1200 x 1200 mm	1200 x 1200 mm	1200 x 1200 mm	1200 x 1200 mm



D-160-D	D-160-G	D-170-1	D-170-2	D-170-3	D-170-4-D
Inter. en T dans une courbe	Inter. en T dans une courbe	Intersection en croix	Intersection en T	Intersection	Intersection en Y à droite
300 x 300 mm	300 x 300 mm	300 x 300 mm	300 x 300 mm	300 x 300 mm	300 x 300 mm
600 x 600 mm	600 x 600 mm	450 x 450 mm	450 x 450 mm	450 x 450 mm	450 x 450 mm
750 x 750 mm	750 x 750 mm	600 x 600 mm	600 x 600 mm	600 x 600 mm	600 x 600 mm
900 x 900 mm	900 x 900 mm	750 x 750 mm	750 x 750 mm	750 x 750 mm	750 x 750 mm
1200 x 1200 mm	1200 x 1200 mm	900 x 900 mm	900 x 900 mm	900 x 900 mm	900 x 900 mm
		1200 x 1200 mm	1200 x 1200 mm	1200 x 1200 mm	1200 x 1200 mm



D-170-4-G	D-170-5-D	D-170-5-G	D-170-6	D-170-10	D-170-11
Intersection en Y à gauche	Intersection à 315°	Intersection à 45°	Intersection en Y	Inter. en T chaussées séparées	Inter. en croix chaussées séparées
300 x 300 mm	300 x 300 mm	300 x 300 mm	300 x 300 mm	600 x 600 mm	600 x 600 mm
450 x 450 mm	450 x 450 mm	450 x 450 mm	450 x 450 mm	750 x 750 mm	750 x 750 mm
600 x 600 mm	600 x 600 mm	600 x 600 mm	600 x 600 mm	900 x 900 mm	900 x 900 mm
750 x 750 mm	750 x 750 mm	750 x 750 mm	750 x 750 mm		
900 x 900 mm	900 x 900 mm	900 x 900 mm	900 x 900 mm		
1200 x 1200 mm	1200 x 1200 mm	1200 x 1200 mm	1200 x 1200 mm		



D-170-12	D-170-13	D-180-1	D-180-2	D-180-3	D-180-4
Intersection	Intersection	Signal avancé passage à niveau	Signal avancé passage à niveau	Signal avancé passage à niveau	Signal avancé passage à niveau
600 x 600 mm	600 x 600 mm	300 x 300 mm	300 x 300 mm	300 x 300 mm	300 x 300 mm
750 x 750 mm	750 x 750 mm	450 x 450 mm	450 x 450 mm	450 x 450 mm	600 x 600 mm
900 x 900 mm	900 x 900 mm	600 x 600 mm	600 x 600 mm	600 x 600 mm	750 x 750 mm
	1200 x 1200 mm	750 x 750 mm	750 x 750 mm	750 x 750 mm	900 x 900 mm
		900 x 900 mm	900 x 900 mm	900 x 900 mm	1200 x 1200 mm
		1200 x 1200 mm	1200 x 1200 mm	1200 x 1200 mm	

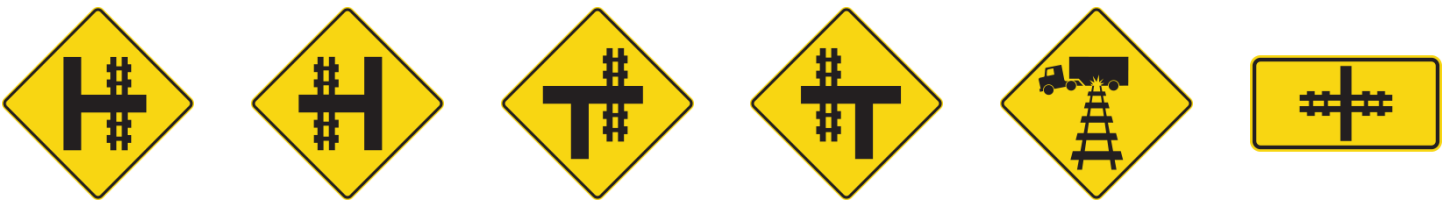

D-180-5-D	D-180-5-G	D-180-6-D	D-180-6-G	D-180-7	D-180-P-1
Signal avancé passage à niveau	Signal avancé passage à niveau	Signal avancé passage à niveau	Signal avancé passage à niveau	Signal avancé passage à niveau	Signal avancé passage à niveau
300 x 300 mm	300 x 300 mm	300 x 300 mm	300 x 300 mm	600 x 600 mm	600 x 300 mm
600 x 600 mm	600 x 600 mm	600 x 600 mm	600 x 600 mm	750 x 750 mm	750 x 380 mm
750 x 750 mm	750 x 750 mm	750 x 750 mm	750 x 750 mm	900 x 900 mm	900 x 450 mm
900 x 900 mm	900 x 900 mm	900 x 900 mm	900 x 900 mm		1200 x 600 mm
1200 x 1200 mm	1200 x 1200 mm	1200 x 1200 mm	1200 x 1200 mm		

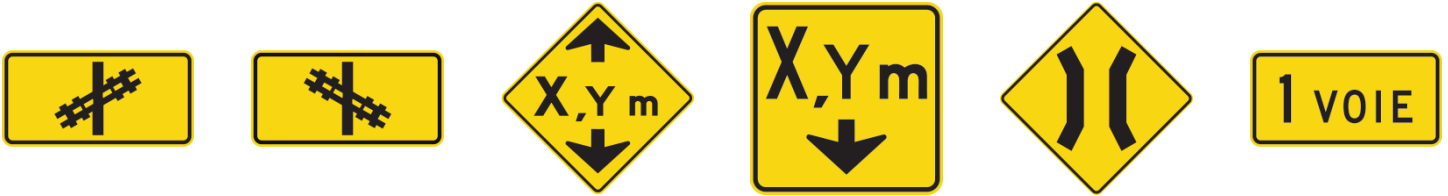

D-180-P-2	D-180-P-3	D-190-1	D-190-2	D-200	D-200-P
Signal avancé passage à niveau	Signal avancé passage à niveau	Signal avancé limite hauteur	Limitation de hauteur	Passage étroit	Une voie
600 x 300 mm	600 x 300 mm	600 x 600 mm	600 x 600 mm	300 x 300 mm	300 x 150 mm
750 x 380 mm	750 x 380 mm	750 x 750 mm	750 x 750 mm	450 x 450 mm	450 x 225 mm
900 x 450 mm	900 x 450 mm	900 x 900 mm	900 x 900 mm	600 x 600 mm	600 x 300 mm
1200 x 600 mm	1200 x 600 mm	1200 x 1200 mm	1200 x 1200 mm	750 x 750 mm	750 x 375 mm
				900 x 900 mm	900 x 450 mm
				1200 x 1200 mm	1200 x 600 mm

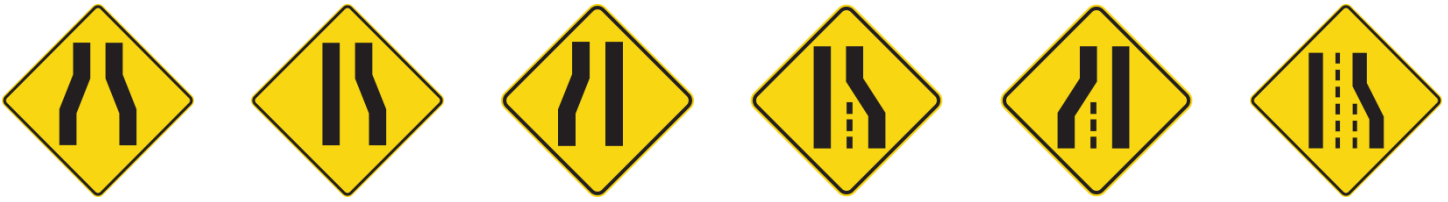

D-210-1	D-210-2-D	D-210-2-G	D-220-1-D	D-220-1-G	D-220-2-D
Chaussée rétrécie	Chaussée rétrécie à droite	Chaussée rétrécie à gauche	Perte de voie à droite	Perte de voie à gauche	Perte de voie à droite
300 x 300 mm	300 x 300 mm	300 x 300 mm	600 x 600 mm	600 x 600 mm	750 x 750 mm
450 x 450 mm	450 x 450 mm	450 x 450 mm	750 x 750 mm	750 x 750 mm	900 x 900 mm
600 x 600 mm	600 x 600 mm	600 x 600 mm	900 x 900 mm	900 x 900 mm	1200 x 1200 mm
750 x 750 mm	750 x 750 mm	750 x 750 mm	1200 x 1200 mm	1200 x 1200 mm	
900 x 900 mm	900 x 900 mm	900 x 900 mm			
1200 x 1200 mm	1200 x 1200 mm	1200 x 1200 mm			



D-220-2-G	D-230-1	D-230-2	D-230-3	D-230-4	D-230-5
Perte de voie à gauche	Pente raide	Pente raide	Pente raide	Pente raide	Pente raide
750 x 750 mm	750 x 750 mm	750 x 750 mm	750 x 750 mm	750 x 750 mm	750 x 750 mm
900 x 900 mm	900 x 900 mm	900 x 900 mm	900 x 900 mm	900 x 900 mm	900 x 900 mm
1200 x 1200 mm	1200 x 1200 mm	1200 x 1200 mm	1200 x 1200 mm	1200 x 1200 mm	1200 x 1200 mm



D-230-6	D-230-P	D-240-1	D-240-2	D-240-P-10-G	D-240-P-10-D
Pente raide	Fin	Visibilité restreinte	Visibilité restreinte	Emplacement	Emplacement
600 x 600 mm	600 x 300 mm	600 x 600 mm	600 x 600 mm	300 x 150 mm	300 x 150 mm
750 x 750 mm	750 x 380 mm	750 x 750 mm	750 x 750 mm	450 x 225 mm	450 x 225 mm
900 x 900 mm	900 x 450 mm	900 x 900 mm	900 x 900 mm	600 x 300 mm	600 x 300 mm
1200 x 1200 mm	1200 x 600 mm	1200 x 1200 mm	1200 x 1200 mm	750 x 380 mm	750 x 380 mm
				900 x 450 mm	900 x 450 mm
				1200 x 600 mm	1200 x 600 mm

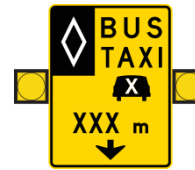
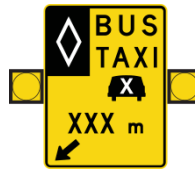

D-245-P-1	D-245-P-2	D-245-P-3	D-250-1	D-250-1-A	D-250-2
<i>Distance</i>	<i>Distance</i>	<i>Distance</i>	<i>Signal avancé voies réservées</i>	<i>Signal avancé voies réservées</i>	<i>Signal avancé voies réservées</i>
300 x 150 mm	300 x 150 mm	600 x 300 mm	900 x 1200 mm	900 x 1200 mm	2400 x 1200 mm
600 x 300 mm	450 x 225 mm	750 x 380 mm			
750 x 380 mm	600 x 300 mm	900 x 450 mm			
900 x 450 mm	750 x 380 mm	1200 x 600 mm			
1200 x 600 mm	900 x 450 mm				
	1200 x 600 mm				



D-250-3	D-250-P	D-250-P-2	D-250-P-3	D-250-P-4	D-255
<i>Signal avancé voies réservées</i>	<i>Signal avancé voies réservées</i>	<i>Étendue / Zone scolaire</i>	<i>Étendue</i>	<i>Étendue</i>	<i>Intersection voie réservée</i>
900 x 1200 mm	750 x 750 mm	300 x 150 mm	450 x 225 mm	600 x 300 mm	600 x 600 mm
	900 x 900 mm	600 x 300 mm	600 x 300 mm	750 x 380 mm	
		750 x 380 mm	750 x 380 mm	900 x 450 mm	
		900 x 450 mm	900 x 450 mm	1200 x 600 mm	
		1200 x 600 mm	1200 x 600 mm		



D-260	D-265-D	D-265-G	D-270-1-D	D-270-1-G	D-270-2-D
<i>Signal avancé arrêt bus scolaires</i>	<i>Début zone scolaire</i>	<i>Début zone scolaire</i>	<i>Signal avancé zone scolaire</i>	<i>Signal avancé zone scolaire</i>	<i>Signal avancé passage piétons</i>
600 x 600 mm	600 x 600 mm	600 x 600 mm	600 x 600 mm	600 x 600 mm	450 x 450 mm
750 x 750 mm	750 x 750 mm	750 x 750 mm	750 x 750 mm	750 x 750 mm	600 x 600 mm
900 x 900 mm	900 x 900 mm	900 x 900 mm	900 x 900 mm	900 x 900 mm	750 x 750 mm
1200 x 1200 mm	1200 x 1200 mm	1200 x 1200 mm	1200 x 1200 mm	1200 x 1200 mm	900 x 900 mm
					1200 x 1200 mm



D-270-2-G	D-270-3-D	D-270-3-G	D-270-4-D	D-270-4-G	D-270-5-D
<i>Signal avancé passage piétons</i>	<i>Signal avancé terrain de jeu</i>	<i>Signal avancé terrain de jeu</i>	<i>Sign. avancé passage pers. déf. physique</i>	<i>Sign. avancé passage pers. déf. physique</i>	<i>Sign. avancé passage pers. déf. visuelle</i>
450 x 450 mm	600 x 600 mm	600 x 600 mm	600 x 600 mm	600 x 600 mm	600 x 600 mm
600 x 600 mm	750 x 750 mm	750 x 750 mm	750 x 750 mm	750 x 750 mm	750 x 750 mm
750 x 750 mm	900 x 900 mm	900 x 900 mm	900 x 900 mm	900 x 900 mm	900 x 900 mm
900 x 900 mm	1200 x 1200 mm	1200 x 1200 mm	1200 x 1200 mm	1200 x 1200 mm	1200 x 1200 mm
1200 x 1200 mm					



D-270-5-G	D-270-6-D	D-270-6-G	D-270-7-D	D-270-7-G	D-270-8
<i>Sign. avancé passage pers. déf. visuelle</i>	<i>Sign. avancé pass. piétons et cyclistes</i>	<i>Sign. avancé pass. piétons et cyclistes</i>	<i>Passage de bicyclettes</i>	<i>Passage de bicyclettes</i>	<i>Passage de quads</i>
600 x 600 mm	450 x 450 mm	450 x 450 mm	300 x 300 mm	300 x 300 mm	300 x 300 mm
750 x 750 mm	600 x 600 mm	600 x 600 mm	450 x 450 mm	450 x 450 mm	600 x 600 mm
900 x 900 mm	750 x 750 mm	750 x 750 mm	600 x 600 mm	600 x 600 mm	750 x 750 mm
1200 x 1200 mm	900 x 900 mm	900 x 900 mm	750 x 750 mm	750 x 750 mm	900 x 900 mm
	1200 x 1200 mm	1200 x 1200 mm	900 x 900 mm	900 x 900 mm	1200 x 1200 mm
			1200 x 1200 mm	1200 x 1200 mm	



D-270-9	D-270-10	D-270-11-D	D-270-11-G	D-270-12	D-270-13
Passage de motoneiges	Passage de motoneiges et quads	Passage de camions	Passage de camions	Passage de cavaliers	Présence possible de chevreuil
300 x 300 mm	600 x 600 mm	600 x 600 mm	600 x 600 mm	300 x 300 mm	300 x 300 mm
600 x 600 mm	750 x 750 mm	750 x 750 mm	750 x 750 mm	600 x 600 mm	600 x 600 mm
750 x 750 mm	900 x 900 mm	900 x 900 mm	900 x 900 mm	750 x 750 mm	750 x 750 mm
900 x 900 mm	1200 x 1200 mm	1200 x 1200 mm	1200 x 1200 mm	900 x 900 mm	900 x 900 mm
1200 x 1200 mm				1200 x 1200 mm	1200 x 1200 mm



D-270-14	D-270-15	D-270-16	D-270-17	D-270-18	D-270-19
Présence possible d'orignaux	Présence possible de caribou	Passage de camions bois longueur	Passage d'animaux de ferme	Passage de sentiers polyvalents	Passage de sentiers polyvalents
300 x 300 mm	300 x 300 mm	600 x 600 mm	600 x 600 mm	600 x 600 mm	600 x 600 mm
600 x 600 mm	600 x 600 mm	750 x 750 mm	750 x 750 mm	750 x 750 mm	750 x 750 mm
750 x 750 mm	750 x 750 mm	900 x 900 mm	900 x 900 mm	900 x 900 mm	900 x 900 mm
900 x 900 mm	900 x 900 mm	1200 x 1200 mm	1200 x 1200 mm	1200 x 1200 mm	1200 x 1200 mm
1200 x 1200 mm	1200 x 1200 mm				



D-270-20	D-280	D-290	D-290-D	D-290-G	D-300-2
Passage de sentiers polyvalents	Fin de voie ou chemin	Balise de danger gauche-droite	Balise de danger droite	Balise de danger gauche	Délinéateur
600 x 600 mm	300 x 300 mm	400 x 600 mm	200 x 600 mm	200 x 600 mm	100 x 200 mm
750 x 750 mm	450 x 450 mm	450 x 1800 mm	300 x 900 mm	300 x 900 mm	
900 x 900 mm	600 x 600 mm	600 x 900 mm	450 x 1200 mm	450 x 1200 mm	
1200 x 1200 mm	750 x 750 mm	900 x 1200 mm	600 x 1800 mm	600 x 1800 mm	
	900 x 900 mm	1200 x 1800 mm			
	1200 x 1200 mm				



D-300-1	D-301-1	D-301-2	D-310-1	D-310-2	D-310-3-D
Délinéateur	Chevron d'alignement	Chevron d'enlignement	Chaussée glissante	Chaussée glissante	Chaussée glissante
100 x 200 mm	300 x 375 mm	1200 x 380 mm	600 x 600 mm	600 x 600 mm	600 x 600 mm
	600 x 750 mm	1800 x 600 mm	750 x 750 mm	750 x 750 mm	750 x 750 mm
	900 x 1200 mm		900 x 900 mm	900 x 900 mm	900 x 900 mm
			1200 x 1200 mm	1200 x 1200 mm	1200 x 1200 mm



D-310-3-G	D-320	D-330	D-340-1	D-340-2	D-350
Chaussée glissante	Chaussée glacée	Chaussée inondée	Changement état chaussée	Changement état chaussée	Fin du revêtement
600 x 600 mm	600 x 600 mm	600 x 600 mm	450 x 450 mm	450 x 450 mm	450 x 450 mm
750 x 750 mm	750 x 750 mm	750 x 750 mm	600 x 600 mm	600 x 600 mm	600 x 600 mm
900 x 900 mm	900 x 900 mm	900 x 900 mm	750 x 750 mm	750 x 750 mm	750 x 750 mm
1200 x 1200 mm	1200 x 1200 mm	1200 x 1200 mm	900 x 900 mm	900 x 900 mm	900 x 900 mm
			1200 x 1200 mm	1200 x 1200 mm	1200 x 1200 mm



D-360	D-361	D-365	D-370-D	D-370-G	D-385
<i>Chaussée cahoteuse</i>	<i>Présence d'un dos d'âne</i>	<i>Trou</i>	<i>Risque chute de pierre</i>	<i>Risque chute de pierre</i>	<i>Visibilité réduite : poudrerie</i>
300 x 300 mm	600 x 600 mm	600 x 600 mm	600 x 600 mm	600 x 600 mm	1800 x 1500 mm
600 x 600 mm			750 x 750 mm	750 x 750 mm	2400 x 2100 mm
750 x 750 mm			900 x 900 mm	900 x 900 mm	3500 x 3050 mm
900 x 900 mm			1200 x 1200 mm	1200 x 1200 mm	
1200 x 1200 mm					



D-390	D-410	D-420-1	D-420-2	D-420-3	D-420-4
<i>Visibilité réduite : brouillard</i>	<i>Signal avancé pont-levis</i>	<i>Vol à basse altitude</i>	<i>Vol à basse altitude</i>	<i>Vol à basse altitude</i>	<i>Vol à basse altitude</i>
1800 x 1200 mm	600 x 600 mm	600 x 600 mm	600 x 600 mm	600 x 600 mm	600 x 600 mm
2400 x 1500 mm	750 x 750 mm	750 x 750 mm	750 x 750 mm	750 x 750 mm	750 x 750 mm
3000 x 2100 mm	900 x 900 mm	900 x 900 mm	900 x 900 mm	900 x 900 mm	900 x 900 mm
	1200 x 1200 mm	1200 x 1200 mm	1200 x 1200 mm	1200 x 1200 mm	1200 x 1200 mm



D-430-1	D-430-2	D-430-3	D-430-6	D-430-7	D-440-1
<i>Signal avancé chaussée désignée</i>	<i>Signal avancé chaussée désignée</i>	<i>Signal avancé chaussée désignée</i>	<i>Signal avancé chaussée désignée</i>	<i>Signal avancé chaussée désignée</i>	<i>Chaussée désignée</i>
450 x 450 mm	300 x 300 mm	300 x 300 mm	300 x 300 mm	300 x 300 mm	600 x 600 mm
600 x 600 mm	600 x 600 mm	600 x 600 mm	600 x 600 mm	600 x 600 mm	750 x 750 mm
750 x 750 mm	750 x 750 mm	750 x 750 mm	750 x 750 mm	750 x 750 mm	900 x 900 mm
900 x 900 mm	900 x 900 mm	900 x 900 mm	900 x 900 mm	900 x 900 mm	1200 x 1200 mm
1200 x 1200 mm	1200 x 1200 mm	1200 x 1200 mm	1200 x 1200 mm	1200 x 1200 mm	



D-440-2	D-440-3	D-440-6	D-440-7	D-450	D-460
<i>Chaussée désignée</i>	<i>Chaussée désignée</i>	<i>Chaussée désignée</i>	<i>Chaussée désignée</i>	<i>Signal avancé accès interdit aux camions</i>	<i>Risque d'enlèvement</i>
600 x 600 mm	600 x 600 mm	600 x 600 mm	600 x 600 mm	600 x 600 mm	600 x 600 mm
750 x 750 mm	750 x 750 mm	750 x 750 mm	750 x 750 mm	750 x 750 mm	750 x 750 mm
900 x 900 mm	900 x 900 mm	900 x 900 mm	900 x 900 mm	900 x 900 mm	900 x 900 mm
1200 x 1200 mm	1200 x 1200 mm	1200 x 1200 mm	1200 x 1200 mm	1200 x 1200 mm	1200 x 1200 mm





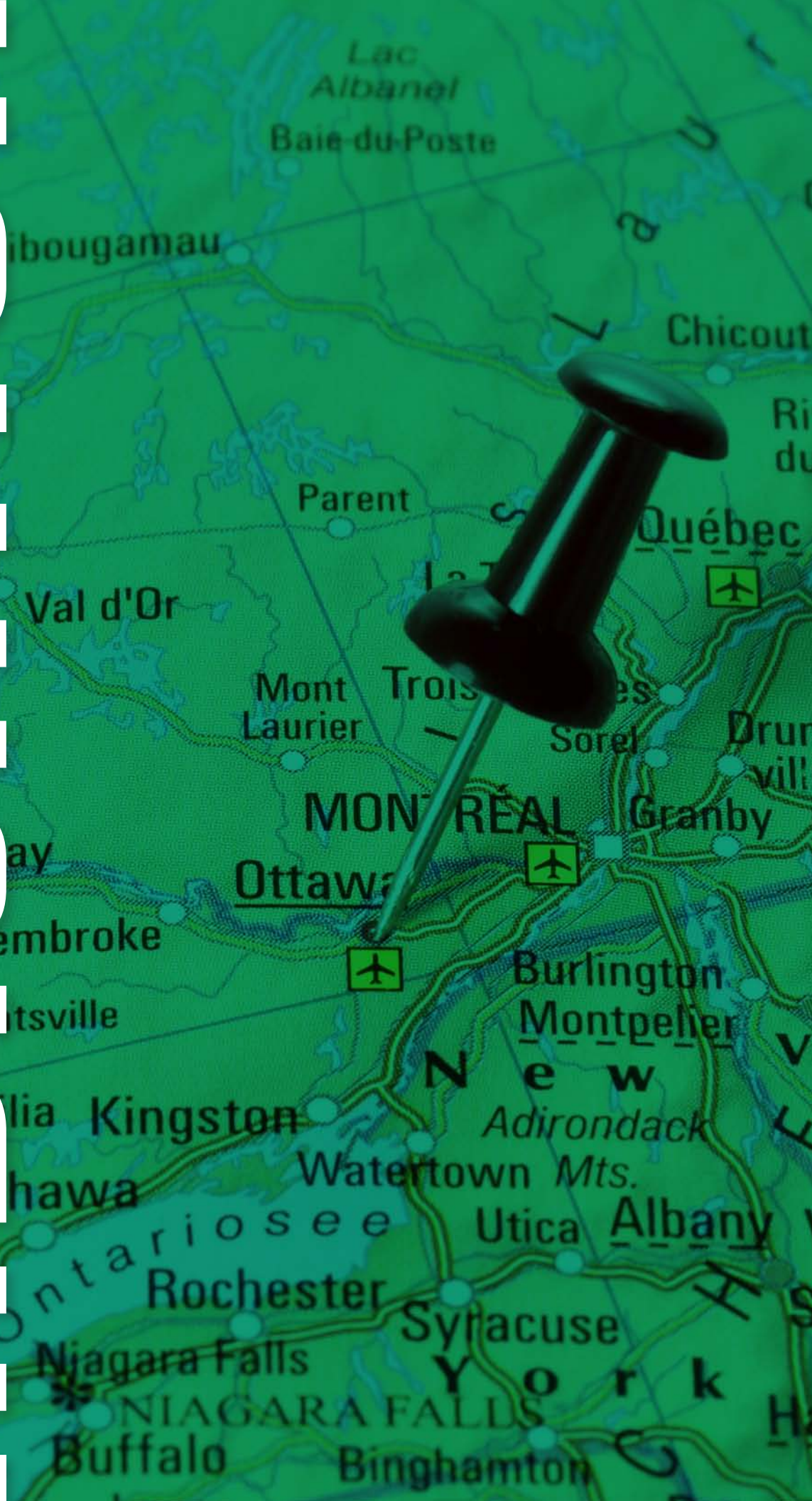

D-470-1	D-470-2	D-470-3	D-500
<i>Signal avancé fin d'autoroute</i>	<i>Signal avancé fin d'autoroute</i>	<i>Signal avancé fin d'autoroute</i>	<i>Soyez visibles</i>
3500 x 2745 mm	3500 x 2745 mm	3500 x 2745 mm	3000 x 1500 mm

# WORLD



## FORMES ET COULEURS DES PANNEAUX

selon les normes du Ministère des Transports du Québec

Forme	Couleur	Description
	Bleu et vert	Réservé aux autoroutes Réservé aux routes
	Vert, brun, bleu et rouge	Autoroutes, routes et voies cyclables Attraits touristiques publics Informations touristiques Équipements d'urgences
	Vert, brun et bleu	Autoroutes, routes et voies cyclables Attraits touris. publics, repères géo. Équipements touristiques privés et services sur autoroutes
	Jaune	Réservé aux sorties d'autoroute





**I-020-1-D**  
Confirmation de sortie  
1200 x 1500 x 900 mm

**I-020-1-D-0**  
Confirmation de sortie  
1200 x 1500 x 900 mm

**I-020-1-G**  
Confirmation de sortie  
1200 x 1500 x 900 mm

**I-020-1-G-0**  
Confirmation de sortie  
1200 x 1500 x 900 mm

**I-020-2**  
Sortie autoroute

**I-030**  
Sortie autoroute



**I-040-1**  
Sortie autoroute

**I-040-2**  
Sortie autoroute

**I-050**  
Sortie autoroute

**I-050-1**  
Sortie autoroute

**I-050-2**  
Sortie autoroute

**I-050-3**  
Sortie autoroute



**I-070-1**  
Sortie autoroute

**I-070-2**  
Sortie autoroute

**I-075-1**  
Sortie autoroute

**I-075-2**  
Sortie autoroute

**I-075-3**  
Sortie autoroute

**I-080**  
Sortie autoroute



**I-090**  
Sortie autoroute

**I-100-1**  
Direction de municipalité  
900 x 300 mm  
1200 x 300 mm  
1500 x 300 mm  
1500 x 450 mm  
1800 x 450 mm  
2400 x 450 mm

**I-100-2**  
Direction de municipalité  
900 x 300 mm  
1200 x 300 mm  
1500 x 300 mm  
1500 x 450 mm  
1800 x 450 mm  
2400 x 450 mm

**I-100-3**  
Direction de municipalité  
900 x 300 mm  
900 x 600 mm  
1200 x 450 mm  
1500 x 600 mm  
1800 x 600 mm  
2400 x 900 mm

**I-100-4**  
Direction de municipalité  
1200 x 450 mm  
1500 x 600 mm  
1800 x 600 mm  
2400 x 900 mm

**I-100-5**  
Direction de municipalité



**I-100-6**  
Direction de municipalité  
1500 x 300 mm  
1500 x 450 mm

**I-110-1**  
Distance de municipalité  
600 x 150 mm  
900 x 150 mm  
900 x 300 mm  
1200 x 300 mm  
1500 x 300 mm  
1800 x 450 mm

**I-110-2**  
Distance de municipalité  
600 x 300 mm  
900 x 300 mm  
900 x 450 mm  
1200 x 450 mm  
1500 x 600 mm  
1800 x 600 mm

**I-115-1**  
Lac de villégiature  
900 x 300 mm  
1200 x 240 mm  
1500 x 300 mm  
1800 x 450 mm  
2400 x 450 mm

**I-115-2**  
Lacs de villégiature  
900 x 450 mm  
1200 x 450 mm  
1500 x 600 mm  
1800 x 600 mm  
2400 x 900 mm

**I-115-3**  
Lacs de villégiature  
900 x 600 mm  
1200 x 750 mm  
1500 x 750 mm  
1800 x 900 mm  
2400 x 1200 mm



Rue des ÉRABLES



I-120-1	I-120-2	I-140	I-150-1	I-150-2	I-150-3
<i>Id. de route numérotée</i>	<i>Identification d'autoroute</i>	<i>Nom de rue</i>	<i>Limite provinciale</i>	<i>Limite provinciale</i>	<i>Entrée de région touristique</i>
450 x 600 mm	450 x 600 mm	900 x 300 mm	1200 x 300 mm	2400 x 1200 mm	2400 x 900 mm
680 x 900 mm	600 x 900 mm	1200 x 300 mm	1800 x 450 mm	4500 x 2135 mm	3500 x 1220 mm
		1500 x 300 mm			
		1800 x 450 mm			
		2400 x 450 mm			
		2400 x 750 mm			



VAL-D'OR

LAC-BROME (Knowlton)

Pont CHAMPLAIN

Pont VICTORIA 1 →

Lac MÉGANTIC

I-150-4	I-150-5	I-160-1	I-160-2	I-170	I-210-1
<i>Entrée d'agglomération</i>	<i>Entrée d'agglomération</i>	<i>Nom de pont</i>	<i>Nom de pont avec distance</i>	<i>Itinéraire transcanadien</i>	<i>Élément hydrographique</i>
600 x 300 mm	1500 x 600 mm	1200 x 450 mm	900 x 300 mm	680 x 900 mm	600 x 150 mm
900 x 300 mm	1500 x 750 mm	1500 x 450 mm	1200 x 300 mm		1200 x 450 mm
1500 x 300 mm	3000 x 915 mm	1800 x 600 mm	1500 x 300 mm		1500 x 300 mm
1500 x 450 mm		2400 x 450 mm	1800 x 450 mm		1800 x 300 mm
3000 x 610 mm		3000 x 610 mm	2400 x 450 mm		2400 x 450 mm

Rivière RICHELIEU

Fleuve ST-LAURENT

Réservoir CABONGA

Chute BLANCHE

Canal de BEAUHARNOIS

Mont ROUEMONT

I-210-2	I-210-3	I-210-4	I-210-5	I-210-6	I-220
<i>Élément hydrographique</i>	<i>Élément hydrographique</i>	<i>Élément hydrographique</i>	<i>Élément hydrographique</i>	<i>Élément hydrographique</i>	<i>Relief géographique</i>
600 x 150 mm	600 x 150 mm	600 x 150 mm	600 x 150 mm	1200 x 240 mm	900 x 150 mm
1200 x 450 mm	1200 x 240 mm	900 x 150 mm	900 x 150 mm	1800 x 300 mm	1200 x 240 mm
1500 x 300 mm	1500 x 300 mm	1200 x 240 mm	1200 x 240 mm		1200 x 450 mm
1800 x 600 mm	1800 x 300 mm				1500 x 300 mm
2400 x 450 mm	2400 x 450 mm				1800 x 300 mm
2400 x 750 mm	3000 x 610 mm				2400 x 450 mm



REPÈRES KILOMÉTRIQUES  
km 125 À km 236

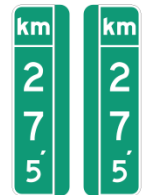

I-260-1	I-260-2	I-260-3	I-260-4	I-260-5	I-260-6
<i>Borne kilométrique</i>	<i>Borne kilométrique</i>	<i>Borne kilométrique</i>	<i>Repères kilométriques</i>	<i>Borne kilométrique</i>	<i>Borne kilométrique</i>
150 x 250 mm	150 x 375 mm	150 x 500 mm	1800 x 450 mm	300 x 750 mm	300 x 1000 mm
300 x 500 mm	300 x 750 mm	300 x 1000 mm			

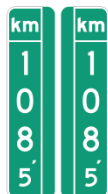

\* 4141  
310-4141

I-260-7	I-260-8	I-270-1	I-270-2	I-270-3	I-270-P
<i>Borne kilométrique</i>	<i>Borne kilométrique</i>	<i>Poste de police logo SQ</i>	<i>Poste de police municipale</i>	<i>Poste de police municipale</i>	<i>Num. de tél. universels</i>
300 x 1200 mm	300 x 1200 mm	600 x 600 mm	600 x 600 mm	600 x 600 mm	600 x 300 mm
		900 x 900 mm	900 x 900 mm	900 x 900 mm	900 x 450 mm
		1200 x 1200 mm	1200 x 1200 mm	1200 x 1200 mm	1200 x 600 mm

# PANONCEAUX DE DIRECTION ET DE DISTANCE



**PANNEAU BLEU : INFORMATIONS TOURISTIQUES**









**PANNEAU ROUGE : ÉQUIPEMENTS D'URGENCE**

















**PANNEAU VERT : AUTOROUTES, ROUTES ET VOIES CYCLABLES**









**PANNEAU BRUN : ATTRAITS TOURISTIQUES PUBLICS**

						
I-200-P-1	I-200-P-2	I-200-P-3	I-200-P-4	I-225-P-1	I-225-P-1	T-010
Point cardinal	Point cardinal	Point cardinal	Point cardinal	Début	Fin	Jonction
•• 300 x 150 mm	•• 300 x 150 mm	•• 300 x 150 mm	•• 300 x 150 mm	•• 300 x 150 mm	•• 300 x 150 mm	•• 300 x 150 mm
• 300 x 200 mm	• 300 x 200 mm	• 300 x 200 mm	• 300 x 200 mm	• 300 x 200 mm	•• 300 x 200 mm	•• 300 x 200 mm
•• 450 x 300 mm	•• 450 x 300 mm	•• 450 x 300 mm	•• 450 x 300 mm	•• 450 x 300 mm	•• 450 x 300 mm	•• 450 x 300 mm
•• 680 x 450 mm	•• 680 x 450 mm	•• 680 x 450 mm	•• 680 x 450 mm		• 600 x 300 mm	•• 680 x 450 mm
					•• 680 x 450 mm	
					• 900 x 450 mm	
					• 1200 x 600 mm	

						
I-240-P-1	I-240-P-2-D	I-240-P-2-G	I-240-P-3-D	I-240-P-3-G	I-240-P-3-G-D	I-240-P-4-D
Direction	Direction	Direction	Direction	Direction	Direction	Direction
•• 300 x 150 mm	•• 300 x 150 mm	•• 300 x 150 mm	•• 300 x 150 mm	•• 300 x 150 mm	•• 300 x 150 mm	•• 300 x 150 mm
• 300 x 200 mm	• 300 x 200 mm	• 300 x 200 mm	• 300 x 200 mm	• 300 x 200 mm	• 300 x 200 mm	• 300 x 200 mm
•• 450 x 300 mm	•• 450 x 300 mm	•• 450 x 300 mm	•• 450 x 300 mm	•• 450 x 300 mm	•• 450 x 300 mm	•• 450 x 300 mm
•• • 600 x 300 mm	•• • 600 x 300 mm	•• • 600 x 300 mm	•• • 600 x 300 mm	•• • 600 x 300 mm	•• • 600 x 300 mm	•• • 600 x 300 mm
•• 680 x 450 mm	•• 680 x 450 mm	•• 680 x 450 mm	•• 680 x 450 mm	•• 680 x 450 mm	•• 680 x 450 mm	•• 680 x 450 mm
•• 750 x 375 mm	•• • 750 x 380 mm	•• 750 x 380 mm	•• • 900 x 450 mm	•• • 900 x 450 mm	•• • 900 x 450 mm	•• • 900 x 450 mm
•• • 900 x 450 mm	•• • 900 x 450 mm	•• • 900 x 450 mm	•• • 1200 x 600 mm	•• • 1200 x 600 mm	•• • 1200 x 600 mm	•• • 1200 x 600 mm
•• 1200 x 600 mm	•• • 1200 x 600 mm	•• 1200 x 600 mm				

						
I-240-P-4-G	I-240-P-5-D	I-240-P-5-G	I-240-P-6	I-240-P-7-D	I-240-P-7-G	I-240-P-8-D
Direction	Direction	Direction	Direction et distance	Direction et distance	Direction et distance	Direction et distance
•• 300 x 150 mm	•• 300 x 150 mm	•• 300 x 150 mm	•• 300 x 150 mm	•• 300 x 150 mm	•• 300 x 150 mm	•• 300 x 150 mm
• 300 x 200 mm	• 300 x 200 mm	• 300 x 200 mm	• 300 x 200 mm	• 300 x 200 mm	• 300 x 200 mm	• 300 x 200 mm
•• 450 x 300 mm	•• 450 x 300 mm	•• 450 x 300 mm	•• 450 x 300 mm	•• 450 x 300 mm	•• 450 x 300 mm	•• 450 x 300 mm
•• • 600 x 300 mm	•• • 600 x 300 mm	•• • 600 x 300 mm	•• • 600 x 300 mm	•• • 600 x 300 mm	•• • 600 x 300 mm	•• • 600 x 300 mm
•• 680 x 450 mm	•• 680 x 450 mm	•• 680 x 450 mm	•• 680 x 450 mm	•• 680 x 450 mm	•• 680 x 450 mm	•• 680 x 450 mm
•• 900 x 450 mm	•• • 900 x 450 mm	•• 900 x 450 mm	•• 750 x 375 mm	•• 750 x 380 mm	•• • 900 x 450 mm	•• 750 x 375 mm
•• 1200 x 600 mm	•• • 1200 x 600 mm	•• 1200 x 600 mm	•• • 900 x 450 mm	•• • 900 x 450 mm	•• • 1200 x 600 mm	•• • 900 x 450 mm
			•• 1200 x 600 mm	•• 1200 x 600 mm		•• 1200 x 600 mm

					
I-240-P-8-G	I-240-P-9-D	I-240-P-9-G	I-245-P-2	I-245-P-3	I-245-P-4
Direction et distance	Direction	Direction	Distance	Distance	Distance
•• 300 x 150 mm	•• 300 x 150 mm	•• 300 x 150 mm	•• • 600 x 300 mm	•• 300 x 150 mm	•• • 600 x 300 mm
• 300 x 200 mm	• 300 x 200 mm	• 300 x 200 mm	•• • 900 x 450 mm	•• • 600 x 300 mm	•• • 900 x 450 mm
•• 450 x 300 mm	•• 450 x 300 mm	•• 450 x 300 mm	•• • 1200 x 600 mm	•• • 750 x 375 mm	•• • 1200 x 600 mm
•• • 600 x 300 mm	•• • 600 x 300 mm	•• • 600 x 300 mm		•• • 900 x 450 mm	
•• 680 x 450 mm	•• 680 x 450 mm	•• 680 x 450 mm		•• • 1200 x 600 mm	
•• 750 x 375 mm	•• • 900 x 450 mm	•• • 900 x 450 mm			
•• • 900 x 450 mm	•• • 1200 x 600 mm	•• • 1200 x 600 mm			
•• 1200 x 600 mm					

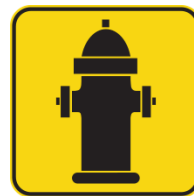

<b>I-280-1</b> <i>Hôpital</i>	<b>I-280-2</b> <i>Centre loc. de serv. communautaires</i>	<b>I-280-3</b> <i>Centre hospitalier uni. vétérinaire</i>	<b>I-285</b> <i>Stationnement d'urgence</i>	<b>I-290</b> <i>Téléphone de secours</i>	<b>I-295-1</b> <i>Borne d'incendie</i>
300 x 300 mm	300 x 300 mm	300 x 300 mm	900 x 900 mm	900 x 900 mm	300 x 300 mm
600 x 600 mm	600 x 600 mm	600 x 600 mm	1200 x 1200 mm	1200 x 1200 mm	450 x 450 mm
900 x 900 mm	900 x 900 mm	900 x 900 mm			
1200 x 1200 mm	1200 x 1200 mm	1200 x 1200 mm			



<b>I-295-2</b> <i>Borne d'incendie</i>	<b>I-298</b> <i>Détecteur de vhc en détresse</i>	<b>I-300-1</b> <i>Aéroport</i>	<b>I-300-2</b> <i>Aéroport</i>	<b>I-300-3</b> <i>Héliport</i>	<b>I-300-4</b> <i>Hydrobase</i>
300 x 450 mm	450 x 1200 mm	600 x 600 mm	600 x 600 mm	600 x 600 mm	600 x 600 mm
450 x 680 mm		900 x 900 mm	750 x 750 mm	900 x 900 mm	900 x 900 mm
		1200 x 1200 mm	900 x 900 mm	1200 x 1200 mm	1200 x 1200 mm
			1200 x 1200 mm		



<b>I-300-P</b> <i>Direction</i>	<b>I-310</b> <i>Gare ferroviaire</i>	<b>I-315</b> <i>Gare d'autocars</i>	<b>I-320-1</b> <i>Traverse maritime sortie distance</i>	<b>I-320-2</b> <i>Traverse maritime sortie direction</i>	<b>I-320-3</b> <i>Traverse maritime direction</i>
600 x 300 mm	600 x 600 mm	600 x 600 mm	3000 x 3050 mm	3000 x 3050 mm	1200 x 1200 mm
900 x 450 mm	900 x 900 mm	900 x 900 mm			1200 x 1800 mm
900 x 600 mm	1200 x 1200 mm	1200 x 1200 mm			1800 x 1800 mm
1200 x 600 mm					3000 x 3050 mm
2400 x 600 mm					



<b>I-320-4</b> <i>Vers traverse maritime</i>	<b>I-320-P</b> <i>Fermé (Traverse maritime)</i>	<b>I-330-1</b> <i>Stationnement train de banlieu</i>	<b>I-330-2</b> <i>Stationnement autobus urbain</i>	<b>I-330-3</b> <i>Stationnement traverse maritime</i>	<b>I-330-4</b> <i>Stationnement station de métro</i>
1200 x 900 mm	1200 x 300 mm	600 x 600 mm	600 x 600 mm	600 x 600 mm	600 x 600 mm
	1800 x 400 mm	900 x 900 mm	900 x 900 mm	900 x 900 mm	900 x 900 mm
	3000 x 610 mm	1200 x 1200 mm	1200 x 1200 mm	1200 x 1200 mm	1200 x 1200 mm



<b>I-340</b> <i>Aire d'attente</i>	<b>I-340-P</b> <i>Aire d'attente</i>	<b>I-350-1</b> <i>Aire de stationnement</i>	<b>I-350-2</b> <i>Aire de stationnement taxi</i>	<b>I-350-3</b> <i>Aire de stationnement autobus</i>	<b>I-350-4</b> <i>Aire de stationnement moto</i>
600 x 600 mm	600 x 300 mm	600 x 600 mm	900 x 600 mm	900 x 600 mm	900 x 600 mm
		900 x 900 mm			
		1200 x 1200 mm			

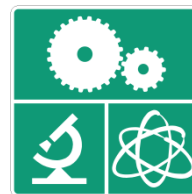

<b>I-350-5</b> <i>Aire de stationnement camion</i>	<b>I-350-6</b> <i>Aire de stationnement 24h</i>	<b>I-355</b> <i>Borne de recharge vhic électr.</i>	<b>I-360</b> <i>Lieu d'enfouissement sanitaire</i>	<b>I-365-1</b> <i>Parc industriel</i>	<b>I-365-2</b> <i>Port maritime</i>
900 x 600 mm 1200 x 900 mm	600 x 600 mm 900 x 900 mm 1200 x 1200 mm	600 x 600 mm 900 x 900 mm	900 x 600 mm 1200 x 900 mm	600 x 600 mm 900 x 900 mm 1200 x 1200 mm	600 x 600 mm 900 x 900 mm 1200 x 1200 mm



<b>I-365-3</b> <i>Parc technologique</i>	<b>I-365-4</b> <i>Université</i>	<b>I-370-1</b> <i>Arène</i>	<b>I-370-2</b> <i>Bibliothèque</i>	<b>I-370-3</b> <i>Centre communautaire</i>	<b>I-370-4</b> <i>Marché public</i>
1800 x 450 mm 2400 x 600 mm	600 x 600 mm 900 x 900 mm 1200 x 1200 mm	600 x 600 mm 900 x 900 mm 1200 x 1200 mm	600 x 600 mm 900 x 900 mm 1200 x 1200 mm	600 x 600 mm 900 x 900 mm 1200 x 1200 mm	600 x 600 mm 900 x 900 mm 1200 x 1200 mm



<b>I-370-5</b> <i>Église</i>	<b>I-370-7</b> <i>Piscine publique intérieure</i>	<b>I-370-8</b> <i>Piscine publique extérieure</i>	<b>I-370-9</b> <i>Parc municipal</i>	<b>I-370-10</b> <i>Cégep</i>	<b>I-370-11</b> <i>Palais de justice</i>
600 x 600 mm 900 x 900 mm 1200 x 1200 mm	600 x 600 mm 900 x 900 mm 1200 x 1200 mm	600 x 600 mm 900 x 900 mm 1200 x 1200 mm	600 x 600 mm 900 x 900 mm 1200 x 1200 mm	600 x 600 mm 900 x 900 mm 1200 x 1200 mm	600 x 600 mm 900 x 900 mm 1200 x 1200 mm



<b>I-370-12</b> <i>Terrain de soccer</i>	<b>I-370-13</b> <i>Terrain de football</i>	<b>I-370-14</b> <i>Terrain de baseball</i>	<b>I-370-15</b> <i>Terrain de soccer intérieure</i>	<b>I-370-16</b> <i>Écocentre</i>	<b>I-370-17</b> <i>Patinoire extérieure</i>
600 x 600 mm 900 x 900 mm 1200 x 1200 mm	600 x 600 mm 900 x 900 mm 1200 x 1200 mm	600 x 600 mm 900 x 900 mm 1200 x 1200 mm	600 x 600 mm 900 x 900 mm 1200 x 1200 mm	600 x 600 mm 900 x 900 mm 1200 x 1200 mm	600 x 600 mm 900 x 900 mm 1200 x 1200 mm



<b>I-370-18</b> <i>Déchetterie</i>	<b>I-370-19</b> <i>Centre de curling</i>	<b>I-371</b> <i>Rampe de mise à l'eau</i>	<b>I-373</b> <i>Poste de douane</i>	<b>I-373-P-1</b> <i>Poste frontalier direction</i>	<b>I-373-P-2</b> <i>Poste frontalier dir. et dist.</i>
900 x 450 mm	600 x 600 mm 900 x 900 mm 1200 x 1200 mm	600 x 600 mm 900 x 900 mm 1200 x 1200 mm	600 x 600 mm 900 x 900 mm 1200 x 1200 mm	600 x 300 mm 900 x 450 mm 1200 x 600 mm	600 x 300 mm 900 x 450 mm 1200 x 600 mm



I-373-P-3	I-373-P-4	I-375-1	I-375-2	I-380	I-385
Poste frontalier horaire et distance	Poste frontalier 24h et distance	Cul-de-sac	Présignalisation cul-de-sac	Demi-tour	Traverse de piétons en diagonale
600 x 450 mm	600 x 450 mm	300 x 150 mm	300 x 150 mm	1200 x 1200 mm	160 x 200 mm
600 x 600 mm	600 x 600 mm	600 x 300 mm	600 x 300 mm		
900 x 600 mm	900 x 600 mm	900 x 450 mm	900 x 450 mm		
900 x 900 mm	900 x 900 mm	1200 x 600 mm	1200 x 600 mm		
1200 x 900 mm	1200 x 900 mm				
1200 x 1200 mm	1200 x 1200 mm				



I-386	I-387	I-390	I-395-1	I-395-1-D	I-395-1-G
Plantation d'arbre	Poste émetteur-récepteur	Priorité de vir. clignotement feu vert	Détecteur de piétons	Détecteur de piétons	Détecteur de piétons
300 x 300 mm	900 x 900 mm 1200 x 1200 mm	600 x 600 mm 900 x 900 mm	160 x 200 mm	160 x 200 mm	160 x 200 mm



I-395-2	I-395-2-D	I-395-2-G	I-395-3	I-395-3-D	I-395-3-G
Détecteur de piétons ou cyclistes	Détecteur de piétons ou cyclistes	Détecteur de piétons ou cyclistes	Détecteur de cyclistes	Détecteur de cyclistes	Détecteur de cyclistes
160 x 200 mm	160 x 200 mm	160 x 200 mm	160 x 200 mm	160 x 200 mm	160 x 200 mm

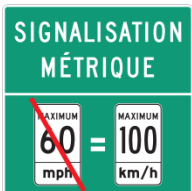

I-400	I-410	I-414	I-415-1	I-415-2	I-416
Signalisation métrique	Surveillance aérienne	Info transports	S.O.S. pente raide	Voie de secours avec lit d'arrêt	Fréquence radio
1200 x 1200 mm 1800 x 1800 mm 2400 x 2400 mm 3500 x 3660 mm	1800 x 900 mm 2400 x 1200 mm 3000 x 1220 mm	900 x 600 mm 1200 x 750 mm 1800 x 1200 mm	1200 x 1200 mm	1200 x 1200 mm	1200 x 900 mm



I-417-1	I-417-2	I-418	I-419-1	I-419-2	I-419-3
Voie de dépasement	Voie de dépasement	Route sans service	Remorquage exclusif début	Remorquage exclusif	Remorquage exclusif fin
600 x 750 mm 900 x 1200 mm	600 x 750 mm 900 x 1200 mm	1200 x 1200 mm	900 x 900 mm 1200 x 1200 mm	900 x 900 mm 1200 x 1200 mm	900 x 900 mm 1200 x 1200 mm



**FERMÉE**

<b>I-419-P</b>	<b>I-420-1</b>	<b>I-420-2</b>	<b>I-420-3</b>	<b>I-420-4</b>	<b>I-420-P</b>
Numéro de téléphone	Halte routière	Halte routière	Halte routière	Halte routière mun. sans services	Fermée pour halte routière
1200 x 600 mm	1800 x 1800 mm 2400 x 2400 mm	1800 x 1800 mm 2400 x 2400 mm	1800 x 1800 mm 2400 x 2400 mm	600 x 600 mm 900 x 900 mm	1800 x 280 mm 2400 x 380 mm



<b>I-430-1</b>	<b>I-430-2</b>	<b>I-450-D</b>	<b>I-450-G</b>	<b>I-510</b>	<b>I-520-2</b>
Aire de repos pour camionneurs	Aire de repos pour camionneurs	Belvédère à droite	Belvédère à gauche	Pont couvert	Centre infotouristique
2400 x 600 mm	2400 x 600 mm	900 x 900 mm	900 x 900 mm	600 x 600 mm 900 x 900 mm 1200 x 1200 mm	3500 x 1525 mm



<b>I-520-3</b>	<b>I-520-4</b>	<b>I-520-5</b>	<b>I-520-6</b>	<b>I-520-7</b>	<b>I-520-8</b>
Centre infotouristique	Centre infotouristique	Centre infotouristique	Centre infotouristique	Centre infotouristique	Centre infotouristique
2400 x 900 mm	1800 x 750 mm	600 x 600 mm 900 x 900 mm 1200 x 1200 mm	1200 x 450 mm 1500 x 600 mm 1800 x 750 mm 2400 x 900 mm 3500 x 1525 mm	1200 x 450 mm 1500 x 600 mm 1800 x 750 mm 2400 x 900 mm	3500 x 1525 mm



<b>I-520-11</b>	<b>I-530-2</b>	<b>I-530-3</b>	<b>I-530-4</b>	<b>I-620-1</b>	<b>I-620-2</b>
Centre infotouristique	Équip. tour. privés sans picto	Équip. tour. privés sans picto	Équip. tour. privés sans picto	Village-relais	Village-relais
600 x 600 mm 900 x 900 mm 1200 x 1200 mm	3500 x 915 mm	600 x 150 mm 900 x 300 mm 1200 x 300 mm 1500 x 375 mm 1800 x 450 mm 2400 x 600 mm	900 x 200 mm 900 x 300 mm 1200 x 300 mm 1500 x 375 mm 1800 x 450 mm 2400 x 600 mm	2400 x 900 mm	2400 x 900 mm



<b>I-620-3</b>	<b>I-620-4</b>	<b>I-650-1</b>	<b>I-650-6</b>
Village-relais	Village-relais picto	Aire de service	Aire de service
2400 x 1200 mm	600 x 600 mm 900 x 900 mm 1200 x 1200 mm	3500 x 1830 mm	600 x 600 mm



PICT-01	PICT-02	PICT-03	PICT-04	PICT-05	PICT-06
<i>Abbaye</i>	<i>Amphithéâtre d'été</i>	<i>Aquarium</i>	<i>Auberge de jeunesse</i>	<i>Autodrome</i>	<i>Belvédère</i>
450 x 450 mm	450 x 450 mm	450 x 450 mm	450 x 450 mm	450 x 450 mm	450 x 450 mm
600 x 600 mm	600 x 600 mm	600 x 600 mm	600 x 600 mm	600 x 600 mm	600 x 600 mm
750 x 750 mm	750 x 750 mm	750 x 750 mm	750 x 750 mm	750 x 750 mm	750 x 750 mm
900 x 900 mm	900 x 900 mm	900 x 900 mm	900 x 900 mm	900 x 900 mm	900 x 900 mm
1200 x 1200 mm	1200 x 1200 mm	1200 x 1200 mm	1200 x 1200 mm	1200 x 1200 mm	1200 x 1200 mm



PICT-07	PICT-08	PICT-09	PICT-10	PICT-11	PICT-12
<i>Boisson à base de petits fruits</i>	<i>Boisson à base de miel</i>	<i>Camp musical</i>	<i>Camping et caravannage</i>	<i>Camping</i>	<i>Canotage</i>
450 x 450 mm	450 x 450 mm	450 x 450 mm	450 x 450 mm	450 x 450 mm	450 x 450 mm
600 x 600 mm	600 x 600 mm	600 x 600 mm	600 x 600 mm	600 x 600 mm	600 x 600 mm
750 x 750 mm	750 x 750 mm	750 x 750 mm	750 x 750 mm	750 x 750 mm	750 x 750 mm
900 x 900 mm	900 x 900 mm	900 x 900 mm	900 x 900 mm	900 x 900 mm	900 x 900 mm
1200 x 1200 mm	1200 x 1200 mm	1200 x 1200 mm	1200 x 1200 mm	1200 x 1200 mm	1200 x 1200 mm



PICT-13	PICT-14	PICT-15	PICT-16	PICT-17	PICT-18
<i>Caravannage</i>	<i>Casino</i>	<i>Centrale énergétique</i>	<i>Centre d'art et galerie d'art</i>	<i>Centre de naturisme</i>	<i>Centre de pêche</i>
450 x 450 mm	450 x 450 mm	450 x 450 mm	450 x 450 mm	450 x 450 mm	450 x 450 mm
600 x 600 mm	600 x 600 mm	600 x 600 mm	600 x 600 mm	600 x 600 mm	600 x 600 mm
750 x 750 mm	750 x 750 mm	750 x 750 mm	750 x 750 mm	750 x 750 mm	750 x 750 mm
900 x 900 mm	900 x 900 mm	900 x 900 mm	900 x 900 mm	900 x 900 mm	900 x 900 mm
1200 x 1200 mm	1200 x 1200 mm	1200 x 1200 mm	1200 x 1200 mm	1200 x 1200 mm	1200 x 1200 mm



PICT-19	PICT-20	PICT-21	PICT-22	PICT-23	PICT-24
<i>Centre de pêche blanche</i>	<i>Centre de ski alpin</i>	<i>Centre de ski de randonnée</i>	<i>Centre de vacances</i>	<i>Centre de villégiature</i>	<i>Centre de vol libre</i>
450 x 450 mm	450 x 450 mm	450 x 450 mm	450 x 450 mm	450 x 450 mm	450 x 450 mm
600 x 600 mm	600 x 600 mm	600 x 600 mm	600 x 600 mm	600 x 600 mm	600 x 600 mm
750 x 750 mm	750 x 750 mm	750 x 750 mm	750 x 750 mm	750 x 750 mm	750 x 750 mm
900 x 900 mm	900 x 900 mm	900 x 900 mm	900 x 900 mm	900 x 900 mm	900 x 900 mm
1200 x 1200 mm	1200 x 1200 mm	1200 x 1200 mm	1200 x 1200 mm	1200 x 1200 mm	1200 x 1200 mm



PICT-25	PICT-26	PICT-27	PICT-28	PICT-29	PICT-30
<i>Centre des métiers d'art</i>	<i>Centre d'interp. ou économusée</i>	<i>Centre équestre</i>	<i>Chute</i>	<i>Ciderie</i>	<i>Auto-cueillette</i>
450 x 450 mm	450 x 450 mm	450 x 450 mm	450 x 450 mm	450 x 450 mm	450 x 450 mm
600 x 600 mm	600 x 600 mm	600 x 600 mm	600 x 600 mm	600 x 600 mm	600 x 600 mm
750 x 750 mm	750 x 750 mm	750 x 750 mm	750 x 750 mm	750 x 750 mm	750 x 750 mm
900 x 900 mm	900 x 900 mm	900 x 900 mm	900 x 900 mm	900 x 900 mm	900 x 900 mm
1200 x 1200 mm	1200 x 1200 mm	1200 x 1200 mm	1200 x 1200 mm	1200 x 1200 mm	1200 x 1200 mm





PICT-31	PICT-32	PICT-33	PICT-34	PICT-35	PICT-36
<i>Début d'un sentier de motoneige</i>	<i>Début d'un sentier de quad</i>	<i>Croisière</i>	<i>Embarcations à moteur</i>	<i>Embarcations à rames</i>	<i>Embarcations à voile</i>
450 x 450 mm	450 x 450 mm	450 x 450 mm	450 x 450 mm	450 x 450 mm	450 x 450 mm
600 x 600 mm	600 x 600 mm	600 x 600 mm	600 x 600 mm	600 x 600 mm	600 x 600 mm
750 x 750 mm	750 x 750 mm	750 x 750 mm	750 x 750 mm	750 x 750 mm	750 x 750 mm
900 x 900 mm	900 x 900 mm	900 x 900 mm	900 x 900 mm	900 x 900 mm	900 x 900 mm
1200 x 1200 mm	1200 x 1200 mm	1200 x 1200 mm	1200 x 1200 mm	1200 x 1200 mm	1200 x 1200 mm



PICT-37	PICT-38	PICT-40	PICT-41	PICT-42	PICT-43
<i>Éolienne</i>	<i>Érablière touristique</i>	<i>Ferme expérimentale</i>	<i>Galerie souterraine</i>	<i>Gîte</i>	<i>Glissade d'eau</i>
450 x 450 mm	450 x 450 mm	450 x 450 mm	450 x 450 mm	450 x 450 mm	450 x 450 mm
600 x 600 mm	600 x 600 mm	600 x 600 mm	600 x 600 mm	600 x 600 mm	600 x 600 mm
750 x 750 mm	750 x 750 mm	750 x 750 mm	750 x 750 mm	750 x 750 mm	750 x 750 mm
900 x 900 mm	900 x 900 mm	900 x 900 mm	900 x 900 mm	900 x 900 mm	900 x 900 mm
1200 x 1200 mm	1200 x 1200 mm	1200 x 1200 mm	1200 x 1200 mm	1200 x 1200 mm	1200 x 1200 mm



PICT-44	PICT-45	PICT-46	PICT-47	PICT-48	PICT-49
<i>Glissade pour luge</i>	<i>Glissade sur chambre à air</i>	<i>Golf</i>	<i>Établiss. hôtelier et rés. de tourisme</i>	<i>Jardin botanique</i>	<i>Jardin zoologique</i>
450 x 450 mm	450 x 450 mm	450 x 450 mm	450 x 450 mm	450 x 450 mm	450 x 450 mm
600 x 600 mm	600 x 600 mm	600 x 600 mm	600 x 600 mm	600 x 600 mm	600 x 600 mm
750 x 750 mm	750 x 750 mm	750 x 750 mm	750 x 750 mm	750 x 750 mm	750 x 750 mm
900 x 900 mm	900 x 900 mm	900 x 900 mm	900 x 900 mm	900 x 900 mm	900 x 900 mm
1200 x 1200 mm	1200 x 1200 mm	1200 x 1200 mm	1200 x 1200 mm	1200 x 1200 mm	1200 x 1200 mm



PICT-50	PICT-51	PICT-52	PICT-53	PICT-54	PICT-55
<i>Kayak</i>	<i>Centre de location de vélos</i>	<i>Marina</i>	<i>Micro-brasserie</i>	<i>Moulin à eau</i>	<i>Moulin à vent</i>
450 x 450 mm	450 x 450 mm	450 x 450 mm	450 x 450 mm	450 x 450 mm	450 x 450 mm
600 x 600 mm	600 x 600 mm	600 x 600 mm	600 x 600 mm	600 x 600 mm	600 x 600 mm
750 x 750 mm	750 x 750 mm	750 x 750 mm	750 x 750 mm	750 x 750 mm	750 x 750 mm
900 x 900 mm	900 x 900 mm	900 x 900 mm	900 x 900 mm	900 x 900 mm	900 x 900 mm
1200 x 1200 mm	1200 x 1200 mm	1200 x 1200 mm	1200 x 1200 mm	1200 x 1200 mm	1200 x 1200 mm



PICT-56	PICT-57	PICT-58	PICT-59	PICT-60	PICT-61
<i>Musée ou économusée</i>	<i>Observatoire</i>	<i>Parachutisme</i>	<i>Passe migratoire</i>	<i>Passerelle</i>	<i>Phare</i>
450 x 450 mm	450 x 450 mm	450 x 450 mm	450 x 450 mm	450 x 450 mm	450 x 450 mm
600 x 600 mm	600 x 600 mm	600 x 600 mm	600 x 600 mm	600 x 600 mm	600 x 600 mm
750 x 750 mm	750 x 750 mm	750 x 750 mm	750 x 750 mm	750 x 750 mm	750 x 750 mm
900 x 900 mm	900 x 900 mm	900 x 900 mm	900 x 900 mm	900 x 900 mm	900 x 900 mm
1200 x 1200 mm	1200 x 1200 mm	1200 x 1200 mm	1200 x 1200 mm	1200 x 1200 mm	1200 x 1200 mm



PICT-62	PICT-63	PICT-64	PICT-65	PICT-66	PICT-67
<i>Plage publique</i>	<i>Planche à voile</i>	<i>Vol à voile</i>	<i>Pourvoirie</i>	<i>Départ d'excursion de raving</i>	<i>Randonnée en traîneaux à chiens</i>
450 x 450 mm	450 x 450 mm	450 x 450 mm	450 x 450 mm	450 x 450 mm	450 x 450 mm
600 x 600 mm	600 x 600 mm	600 x 600 mm	600 x 600 mm	600 x 600 mm	600 x 600 mm
750 x 750 mm	750 x 750 mm	750 x 750 mm	750 x 750 mm	750 x 750 mm	750 x 750 mm
900 x 900 mm	900 x 900 mm	900 x 900 mm	900 x 900 mm	900 x 900 mm	900 x 900 mm
1200 x 1200 mm	1200 x 1200 mm	1200 x 1200 mm	1200 x 1200 mm	1200 x 1200 mm	1200 x 1200 mm



PICT-68	PICT-69	PICT-70	PICT-71	PICT-73	PICT-74
<i>Sanctuaire religieux</i>	<i>Sentier de randonnée à raquette</i>	<i>Sentier de randonnée pédestre</i>	<i>Site archéologique</i>	<i>Station touristique</i>	<i>Théâtre d'été</i>
450 x 450 mm	450 x 450 mm	450 x 450 mm	450 x 450 mm	450 x 450 mm	450 x 450 mm
600 x 600 mm	600 x 600 mm	600 x 600 mm	600 x 600 mm	600 x 600 mm	600 x 600 mm
750 x 750 mm	750 x 750 mm	750 x 750 mm	750 x 750 mm	750 x 750 mm	750 x 750 mm
900 x 900 mm	900 x 900 mm	900 x 900 mm	900 x 900 mm	900 x 900 mm	900 x 900 mm
1200 x 1200 mm	1200 x 1200 mm	1200 x 1200 mm	1200 x 1200 mm	1200 x 1200 mm	1200 x 1200 mm



PICT-75	PICT-76	PICT-77	PICT-78	PICT-79	PICT-80
<i>Vélo de montagne</i>	<i>Vignoble</i>	<i>Visite de mines</i>	<i>Visite industrielle</i>	<i>Zone d'exploitation contrôlée</i>	<i>Centre de congrès, foire ou expo</i>
450 x 450 mm	450 x 450 mm	450 x 450 mm	450 x 450 mm	450 x 450 mm	450 x 450 mm
600 x 600 mm	600 x 600 mm	600 x 600 mm	600 x 600 mm	600 x 600 mm	600 x 600 mm
750 x 750 mm	750 x 750 mm	750 x 750 mm	750 x 750 mm	750 x 750 mm	750 x 750 mm
900 x 900 mm	900 x 900 mm	900 x 900 mm	900 x 900 mm	900 x 900 mm	900 x 900 mm
1200 x 1200 mm	1200 x 1200 mm	1200 x 1200 mm	1200 x 1200 mm	1200 x 1200 mm	1200 x 1200 mm



PICT-82	PICT-83	PICT-84	PICT-85	PICT-86	PICT-87
<i>Centre de karting</i>	<i>Train touristique</i>	<i>Centre de plein air</i>	<i>Jardin zoologique</i>	<i>Parc et forêt habités</i>	<i>Parc et forêt habités</i>
450 x 450 mm	450 x 450 mm	450 x 450 mm	450 x 450 mm	450 x 450 mm	450 x 450 mm
600 x 600 mm	600 x 600 mm	600 x 600 mm	600 x 600 mm	600 x 600 mm	600 x 600 mm
750 x 750 mm	750 x 750 mm	750 x 750 mm	750 x 750 mm	750 x 750 mm	750 x 750 mm
900 x 900 mm	900 x 900 mm	900 x 900 mm	900 x 900 mm	900 x 900 mm	900 x 900 mm
1200 x 1200 mm	1200 x 1200 mm	1200 x 1200 mm	1200 x 1200 mm	1200 x 1200 mm	1200 x 1200 mm



PICT-88	PICT-89	PICT-90	PICT-91	PICT-92	PICT-93
<i>Poterie</i>	<i>Soufflage de verre</i>	<i>Boisson à base de produits d'érable</i>	<i>Centre d'escalade et canyoning</i>	<i>Excursion touristique commentée</i>	<i>Ferme agrotouristique</i>
450 x 450 mm	450 x 450 mm	450 x 450 mm	450 x 450 mm	450 x 450 mm	450 x 450 mm
600 x 600 mm	600 x 600 mm	600 x 600 mm	600 x 600 mm	600 x 600 mm	600 x 600 mm
750 x 750 mm	750 x 750 mm	750 x 750 mm	750 x 750 mm	750 x 750 mm	750 x 750 mm
900 x 900 mm	900 x 900 mm	900 x 900 mm	900 x 900 mm	900 x 900 mm	900 x 900 mm
1200 x 1200 mm	1200 x 1200 mm	1200 x 1200 mm	1200 x 1200 mm	1200 x 1200 mm	1200 x 1200 mm



PICT-94	PICT-95	PICT-96	PICT-97	PICT-98	PICT-99
<i>Hébertisme aérien</i>	<i>Centre d'observation de la faune</i>	<i>Visite d'entreprise</i>	<i>Centre de détente / Spa</i>	<i>Excursion touristique en hydravion</i>	<i>Fromagerie</i>
450 x 450 mm	450 x 450 mm	450 x 450 mm	450 x 450 mm	450 x 450 mm	450 x 450 mm
600 x 600 mm	600 x 600 mm	600 x 600 mm	600 x 600 mm	600 x 600 mm	600 x 600 mm
750 x 750 mm	750 x 750 mm	750 x 750 mm	750 x 750 mm	750 x 750 mm	750 x 750 mm
900 x 900 mm	900 x 900 mm	900 x 900 mm	900 x 900 mm	900 x 900 mm	900 x 900 mm
1200 x 1200 mm	1200 x 1200 mm	1200 x 1200 mm	1200 x 1200 mm	1200 x 1200 mm	1200 x 1200 mm



PICT-100	PICT-101	PICT-102	PICT-103	PICT-104	PICT-105
<i>Hébergement en igloo</i>	<i>Hébergement en tipi</i>	<i>Site ornithologique</i>	<i>Vélodrome</i>	<i>Saut à l'élastique (bungee)</i>	<i>Sculpture</i>
450 x 450 mm	450 x 450 mm	450 x 450 mm	450 x 450 mm	450 x 450 mm	450 x 450 mm
600 x 600 mm	600 x 600 mm	600 x 600 mm	600 x 600 mm	600 x 600 mm	600 x 600 mm
750 x 750 mm	750 x 750 mm	750 x 750 mm	750 x 750 mm	750 x 750 mm	750 x 750 mm
900 x 900 mm	900 x 900 mm	900 x 900 mm	900 x 900 mm	900 x 900 mm	900 x 900 mm
1200 x 1200 mm	1200 x 1200 mm	1200 x 1200 mm	1200 x 1200 mm	1200 x 1200 mm	1200 x 1200 mm



PICT-106	PICT-107	PICT-108	PICT-109	PICT-110	PICT-111
<i>Hippodrome</i>	<i>Excursion touristique en hélicoptère</i>	<i>Monument commémoratif</i>	<i>Paintball</i>	<i>Auto-cueillette de sapin</i>	<i>Parc éolien</i>
450 x 450 mm	450 x 450 mm	450 x 450 mm	450 x 450 mm	450 x 450 mm	450 x 450 mm
600 x 600 mm	600 x 600 mm	600 x 600 mm	600 x 600 mm	600 x 600 mm	600 x 600 mm
750 x 750 mm	750 x 750 mm	750 x 750 mm	750 x 750 mm	750 x 750 mm	750 x 750 mm
900 x 900 mm	900 x 900 mm	900 x 900 mm	900 x 900 mm	900 x 900 mm	900 x 900 mm
1200 x 1200 mm	1200 x 1200 mm	1200 x 1200 mm	1200 x 1200 mm	1200 x 1200 mm	1200 x 1200 mm



PICT-112	PICT-113	PICT-114	PICT-115
<i>Parc olympique</i>	<i>Parc d'attraction</i>	<i>Cosmodôme</i>	<i>Biodôme</i>
450 x 450 mm	450 x 450 mm	450 x 450 mm	450 x 450 mm
600 x 600 mm	600 x 600 mm	600 x 600 mm	600 x 600 mm
750 x 750 mm	750 x 750 mm	750 x 750 mm	750 x 750 mm
900 x 900 mm	900 x 900 mm	900 x 900 mm	900 x 900 mm
1200 x 1200 mm	1200 x 1200 mm	1200 x 1200 mm	1200 x 1200 mm

# LOUEZ-MOI

## REMORQUE RADAR



\* Tarif pour location mensuelle

**SENSIBILISEZ LES AUTOMOBILISTES  
AU RESPECT DES LIMITES DE VITESSE**

Location : • JOUR  
• SEMAINE  
• MOIS

Permet de récolter plus de  
2000 données par semaine

Afficheur de vitesse à LEDs

Service de livraison



## PANNEAU À MESSAGE VARIABLE



\* Tarif pour location mensuelle

**IDÉAL POUR FAIRE PASSER UN MESSAGE  
CLAIR À TOUS LES AUTOMOBILISTES ET  
USAGÉS DE LA ROUTE**

Permet d'afficher un message de  
trois lignes de douze caractères  
majuscules et/ou un pictogramme

Visibilité à 500m

Location : • JOUR  
• SEMAINE  
• MOIS

Service de livraison



# VOIES CYCLABLES



<b>PC-1-P</b> Bicyclette 450 x 300 mm	<b>PC-010</b> Arrêt 450 x 450 mm	<b>PC-020-1</b> Cédez le passage 450 x 450 mm	<b>PC-040</b> Entrée interdite 450 x 450 mm	<b>PC-080-1</b> Sens unique 450 x 150 mm	<b>PC-110-1</b> Obligation d'aller tout droit 450 x 450 mm
<b>PC-110-2-D</b> Obligation tourner à droite 450 x 450 mm	<b>PC-110-2-G</b> Obligation tourner à gauche 450 x 450 mm	<b>PC-110-3-G</b> Oblig. aller tout droit ou à gauche 450 x 450 mm	<b>PC-110-3-D</b> Oblig. aller tout droit ou à droite 450 x 450 mm	<b>PC-110-4</b> Oblig. d'aller à gauche ou à droite 450 x 450 mm	<b>PC-110-5</b> Interdit de faire demi-tour 450 x 450 mm
<b>PC-110-7-G</b> Interdit de tourner à gauche 450 x 450 mm	<b>PC-110-7-D</b> Interdit de tourner à droite 450 x 450 mm	<b>PC-110-8</b> Interdit d'aller tout droit 450 x 450 mm	<b>PC-110-P-5</b> Excepté bicyclettes 450 x 450 mm 600 x 600 mm	<b>PC-120-9</b> Trajet oblig. pour cyclistes 450 x 450 mm	<b>PC-120-10-D</b> Trajet oblig. séparés cyclistes et piétons 450 x 450 mm
<b>PC-120-10-G</b> Trajet oblig. séparés cyclistes et piétons 450 x 450 mm	<b>PC-120-11</b> Trajet oblig. mixte cyclistes et piétons 450 x 450 mm	<b>PC-120-100</b> Oblig. garder chien en laisse 450 x 450 mm	<b>PC-120-102</b> Oblig. ramasser besoins de chien 450 x 450 mm	<b>PC-125</b> Oblig. descendre de bicyclette 450 x 450 mm	<b>PC-126</b> Oblig. circuler avec un adulte 450 x 900 mm
<b>PC-130-4</b> Accès interdit aux automobiles 450 x 450 mm	<b>PC-130-5</b> Accès interdit aux motocyclettes 450 x 450 mm	<b>PC-130-6</b> Accès interdit aux bicyclettes 450 x 450 mm	<b>PC-130-7</b> Accès interdit aux quads 450 x 450 mm	<b>PC-130-12</b> Accès interdit aux piétons 450 x 450 mm	<b>PC-130-13</b> Accès interdit aux cavaliers 450 x 450 mm
<b>PC-130-14</b> Accès interdit aux motoneiges 450 x 450 mm	<b>PC-130-28</b> Acc. interdit aux pat. roues alignées 450 x 450 mm	<b>PC-140-2</b> Interdiction de dépasser 450 x 450 mm	<b>PC-150-2</b> Stationnement réglementé 300 x 450 mm	<b>PC-150-2-D</b> Stationnement réglementé 300 x 450 mm	<b>PC-150-2-G</b> Stationnement réglementé 300 x 450 mm



**PC-150-2-G-D**  
Stationnement réglementé  
300 x 450 mm



**PC-150-7**  
Stationnement autorisé  
300 x 450 mm



**PC-150-7-D**  
Stationnement autorisé  
300 x 450 mm



**PC-150-7-G**  
Stationnement autorisé  
300 x 450 mm

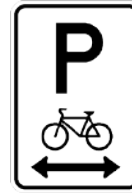

**PC-150-7-G-D**  
Stationnement autorisé  
300 x 450 mm



**PC-160-1**  
Arrêt interdit  
300 x 450 mm



**PC-160-1-D**  
Arrêt interdit  
300 x 450 mm



**PC-160-1-G**  
Arrêt interdit  
300 x 450 mm



**PC-160-1-G-D**  
Arrêt interdit  
300 x 450 mm



**PC-225**  
Trajet oblig. voie dépasement  
300 x 450 mm



**PC-240-P-1**  
Direction  
450 x 250 mm  
600 x 300 mm



**PC-240-P-2-D**  
Direction  
450 x 250 mm  
600 x 300 mm



**PC-240-P-2-G**  
Direction  
450 x 250 mm  
600 x 300 mm



**PC-240-P-3**  
Direction  
450 x 250 mm  
600 x 300 mm



**PC-240-P-3-G-D**  
Direction  
450 x 250 mm  
600 x 300 mm



**PC-240-P-4-D**  
Direction  
450 x 250 mm  
600 x 300 mm



**PC-240-P-4-G**  
Direction  
450 x 250 mm  
600 x 300 mm



**PC-240-P-5-D**  
Direction  
450 x 250 mm  
600 x 300 mm



**PC-240-P-5-G**  
Direction  
450 x 250 mm  
600 x 300 mm



**PC-240-P-9-D**  
Direction  
450 x 250 mm  
600 x 300 mm



**PC-240-P-9-G**  
Direction  
450 x 250 mm  
600 x 300 mm

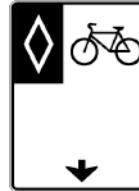

**PC-250-1**  
Voie réservée aux bicyclettes  
600 x 750 mm

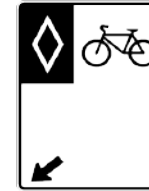

**PC-250-2**  
Voie réservée aux bicyclettes  
600 x 750 mm



**PC-250-3**  
Voie réservée aux bicyclettes  
600 x 750 mm



**PC-250-6**  
Voie réservée aux bicyclettes  
600 x 600 mm



**PC-270-2-D**  
Passage pour piétons  
450 x 600 mm



**PC-270-2-G**  
Passage pour piétons  
450 x 600 mm



**PC-270-6-D**  
Passage pour piétons et cyclistes  
450 x 600 mm

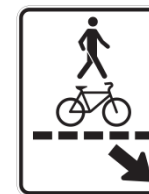

**PC-270-6-G**  
Passage pour piétons et cyclistes  
450 x 600 mm



**PC-285**  
Presc. pour cyclistes au feu piétons  
300 x 450 mm



**PC-310**  
Défense de jeter des ordures  
450 x 450 mm



**DC-1-P**  
Bicyclette  
450 x 300 mm



**DC-010-1**  
Signal avancé arrêt  
450 x 450 mm



**DC-020**  
Signal avancé cédez le passage  
450 x 450 mm



**DC-050-1**  
Signal avancé feux de circ.  
450 x 450 mm



**DC-110-1-D**  
Virage à droite  
450 x 450 mm



**DC-110-1-G**

*Virage à gauche*

450 x 450 mm



**DC-110-2-D**

*Virage à droite*

450 x 450 mm



**DC-110-2-G**

*Virage à gauche*

450 x 450 mm



**DC-130-1**

*Flèche directionnelle*

450 x 450 mm



**DC-130-2**

*Flèche directionnelle*

450 x 450 mm



**DC-170-1**

*Intersection en croix*

450 x 450 mm



**DC-170-2**

*Intersection en T*

450 x 450 mm



**DC-170-3**

*Intersection*

450 x 450 mm



**DC-170-4-D**

*Intersection en Y à droite*

450 x 450 mm



**DC-170-4-G**

*Intersection en Y à gauche*

450 x 450 mm



**DC-170-6**

*Intersection en Y*

450 x 450 mm



**DC-180-1**

*Sign. avancé passage à niveau*

450 x 450 mm



**DC-180-2**

*Sign. avancé passage à niveau*

450 x 450 mm



**DC-180-3**

*Sign. avancé passage à niveau*

450 x 450 mm



**DC-200**

*Passage étroit*

450 x 450 mm



**DC-200-P-2**

*Passage 1 voie*

450 x 225 mm



**DC-210-1**

*Chaussée rétrécie*

450 x 450 mm



**DC-210-2-D**

*Chaussée rétrécie à droite*

450 x 450 mm



**DC-210-2-G**

*Chaussée rétrécie à gauche*

450 x 450 mm



**DC-230-7**

*Pente raide*

450 x 450 mm



**DC-230-8**

*Pente raide*

450 x 450 mm



**DC-240-P-10-D**

*Emplacement*

450 x 225 mm



**DC-240-P-10-G**

*Emplacement*

450 x 225 mm



**DC-245-P-1**

*Distance*

450 x 225 mm



**DC-245-P-2**

*Distance*

450 x 225 mm



**DC-245-P-3**

*Distance*

450 x 225 mm



**DC-250-P-2**

*Étendue*

450 x 225 mm



**DC-250-P-3**

*Étendue*

450 x 225 mm



**DC-270-2-D**

*Sign. avancé passage piétons*

450 x 450 mm



**DC-270-2-G**

*Sign. avancé passage piétons*

450 x 450 mm



**DC-270-6-D**

*Sign. avancé pass. piétons et bicyclettes*

450 x 450 mm



**DC-270-6-G**

*Sign. avancé pass. piétons et bicyclettes*

450 x 450 mm



**DC-270-7-D**

*Sign. avancé passage bicyclettes*

450 x 450 mm



**DC-270-7-G**

*Sign. avancé passage bicyclettes*

450 x 450 mm



**DC-275**

*Accès public fréquenté*

450 x 450 mm



**DC-280**

*Fin d'une piste cyclable*

450 x 450 mm





**DC-290**  
Balise de danger gauche droite  
400 x 600 mm



**DC-290-D**  
Balise de danger à droite  
200 x 600 mm



**DC-290-G**  
Balise de danger à gauche  
200 x 600 mm



**DC-301-1**  
Chevron d'alignement  
300 x 375 mm



**DC-310-4**  
Caussée glissante  
450 x 450 mm



**DC-340**  
Changement de l'état d'une chaussée  
450 x 450 mm



**DC-350**  
Fin du revêtement  
450 x 450 mm



**DC-430-1**  
Sign. avancé de chaussée désignée  
450 x 450 mm



**DC-440-1**  
Chaussée désign. auto. et bicyclettes  
450 x 450 mm



**TC-080-8**  
Voie cyclable barrée  
450 x 450 mm



**TC-090-6-D**  
Détour  
450 x 450 mm



**TC-090-6-G**  
Détour  
450 x 450 mm



**TC-090-7**  
Détour  
450 x 450 mm



**TC-090-8-D**  
Détour  
450 x 450 mm



**TC-090-8-G**  
Détour  
450 x 450 mm



**TC-090-13-D**  
Détour piétons et cyclistes  
450 x 450 mm



**TC-090-13-G**  
Détour piétons et cyclistes  
450 x 450 mm



**TC-090-14**  
Détour piétons et cyclistes  
450 x 450 mm



**TC-090-15-D**  
Détour piétons et cyclistes  
450 x 450 mm



**TC-090-15-G**  
Détour piétons et cyclistes  
450 x 450 mm



**TC-090-16-D**  
Détour piétons  
450 x 450 mm



**TC-090-16-G**  
Détour piétons  
450 x 450 mm



**TC-090-17**  
Détour piétons  
450 x 450 mm



**TC-090-18-D**  
Détour piétons  
450 x 450 mm



**TC-090-18-G**  
Détour piétons  
450 x 450 mm



**IC-095**  
Ach. et id. de voies cyclables  
900 x 300 mm  
900 x 450 mm



**IC-105**  
Id. d'une voie cyclable  
450 x 300 mm



**IC-135**  
Id. de la route verte  
300 x 400 mm



**IC-150-3**  
Entrée de région touristique  
600 x 225 mm



**IC-150-4**  
Entrée d'agglomération  
600 x 300 mm



**IC-210-1**  
Élément hydrographique  
600 x 150 mm

**IC-210-2**  
Élément hydrographique  
600 x 150 mm

**IC-210-3**  
Élément hydrographique  
600 x 150 mm

**IC-210-4**  
Élément hydrographique  
600 x 150 mm

**IC-210-5**  
Élément hydrographique  
600 x 150 mm

**IC-230-P-V**  
Fin  
300 x 200 mm  
450 x 300 mm



IC-235-P-V

IC-240-P-1-V

IC-240-P-2-D-V

IC-240-P-2-G-V

IC-240-P-3-D-V

IC-240-P-3-G-D-V

Jonction

Direction

Direction

Direction

Direction

Direction

300 x 200 mm  
450 x 300 mm

300 x 200 mm  
450 x 300 mm

300 x 200 mm  
450 x 300 mm

300 x 200 mm  
450 x 300 mm

300 x 200 mm  
450 x 300 mm

300 x 200 mm  
450 x 300 mm



IC-240-P-3-G-V

IC-240-P-4-D-V

IC-240-P-4-G-V

IC-240-P-5-D-V

IC-240-P-5-G-V

IC-240-P-6-V

Direction

Direction

Direction

Direction

Direction

Direction et distance

300 x 200 mm  
450 x 300 mm

300 x 200 mm  
450 x 300 mm

300 x 200 mm  
450 x 300 mm

300 x 200 mm  
450 x 300 mm

300 x 200 mm  
450 x 300 mm

300 x 200 mm  
450 x 300 mm



IC-240-P-7-D-V

IC-240-P-7-G-V

IC-240-P-8-D-V

IC-240-P-8-G-V

IC-240-P-9-D-V

IC-240-P-9-G-V

Direction et distance

Direction et distance

Direction et distance

Direction et distance

Direction

Direction

300 x 200 mm  
450 x 300 mm

300 x 200 mm  
450 x 300 mm

300 x 200 mm  
450 x 300 mm

300 x 200 mm  
450 x 300 mm

300 x 200 mm  
450 x 300 mm

300 x 200 mm  
450 x 300 mm



IC-260-1

IC-260-2

IC-260-3

IC-350-7

IC-350-8

IC-372

Borne kilométrique

Borne kilométrique

Borne kilométrique

Aire de stat. bicyclettes

Aire de stat. connexe

Pér. fermeture pistes cyclables

150 x 250 mm

150 x 375 mm

150 x 500 mm

450 x 450 mm

1200 x 450 mm

450 x 450 mm



IC-395-2

IC-395-2-D

IC-395-2-G

IC-395-3

IC-395-3-D

IC-395-3-G

Dét. de piétons ou cyclistes

Dét. de piétons ou cyclistes

Dét. de piétons ou cyclistes

Détecteur de cyclistes

Détecteur de cyclistes

Détecteur de cyclistes

160 x 200 mm

160 x 200 mm

160 x 200 mm

160 x 200 mm

160 x 200 mm

160 x 200 mm



IC-420-4

IC-520-5

IC-530-3

IC-535-A

IC-535-B

IC-535-C

Halte routière

Centre infotouriste

Achem. équip. tour. privés

Achem. itinéraire cyc. hors rte

Achem. itinéraire cyc. hors rte

Achem. itinéraire cyc. hors rte

450 x 450 mm

450 x 450 mm

600 x 150 mm

450 x 450 mm  
600 x 600 mm

450 x 450 mm  
600 x 600 mm

450 x 450 mm  
600 x 600 mm



**IC-535-D**

**IC-535-E**

**IC-600-1**

**IC-600-2**

**IC-600-3**

**IC-600-4**

Achem. itinéraire cyc. hors rte  
450 x 450 mm  
600 x 600 mm

Achem. itinéraire cyc. hors rte  
450 x 450 mm  
600 x 600 mm

Services publics, abri  
450 x 450 mm

Services publics, abri chauffé  
450 x 450 mm

Services publics, eau potable  
450 x 450 mm

Services publics, pompe à air  
450 x 450 mm



**IC-600-5**

**IC-600-6**

**IC-610-1**

**IC-610-2**

**IC-700-1**

**IC-700-2**

Services publics, téléphone  
450 x 450 mm

Services publics, toilettes  
450 x 450 mm

Sign. des services commerciaux  
600 x 150 mm

Sign. des services commerciaux  
600 x 150 mm

Signalisation frontalière  
600 x 150 mm

Signalisation frontalière  
600 x 150 mm



# THE NEW TRIP BOOK FOR SKIERS



# SKI ALPIN



S-080

Facile

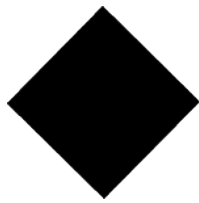

S-081

Très difficile



S-082

Difficile



S-083

Extrême



S-084

Numérotage



S-085

Piste avec bosses



S-086

Lettre



S-087

Sous-bois



S-088

Flèche



S-090

Panneau indicateur



S-091

Nom de la piste

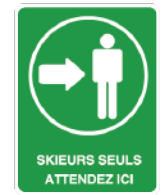

S-100

Skieurs seuls attendez ici

450 x 600 mm



S-101

Remontées simples

450 x 600 mm



S-102

Remontées doubles

450 x 600 mm



S-103

Remontées triples

450 x 600 mm



S-104

Remontées quadruples

450 x 600 mm

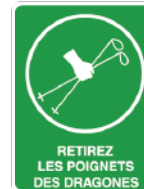

S-105

Retirez les poignets des dragonnons

450 x 600 mm



S-106

Attachez bien vos vêtements

450 x 600 mm



S-107

Information

450 x 600 mm



S-108

Téléphone d'urgence

300 x 300 mm



S-109

Arrêt d'urgence

300 x 150 mm



S-110

Remontée fermée

450 x 600 mm



S-111

Remontée fermée

300 x 150 mm



S-112

Endroit où se placer

700 x 700 mm



S-113

Frein d'urgence

300 x 150 mm



S-114

Heure de la dernière remontée

450 x 600 mm



S-115

Emplacement des billets

450 x 600 mm

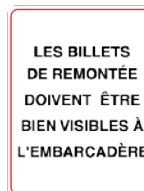

S-116

Emplacement des billets

450 x 600 mm



S-120

Barre de sécurité doit être baissée

450 x 600 mm



S-121

Ne pas faire balancer les sièges

450 x 600 mm



S-122

Relevez la barre

450 x 600 mm



S-123

Relevez les spatules

450 x 600 mm



S-140

Ne pas enfourcher

450 x 600 mm



S-141

Restez sur la piste

450 x 600 mm



S-142

En cas de chute

450 x 600 mm



S-143

En cas de chute

450 x 600 mm

<b>S-144</b> Sentier d'urgence 600 x 300 mm	<b>S-145</b> Ne pas rattraper 450 x 600 mm	<b>S-160</b> Distance avant de descendre 450 x 600 mm	<b>S-161</b> Distance avant de descendre 450 x 600 mm	<b>S-162</b> Distance avant de descendre 450 x 600 mm	<b>S-163</b> Descendez 450 x 600 mm
<b>S-164</b> Descendez 450 x 600 mm	<b>S-165</b> Descendez 450 x 600 mm	<b>S-166</b> Descendez ici 450 x 600 mm	<b>S-167</b> Descendez ici 450 x 600 mm	<b>S-168</b> Barrière de sécurité 450 x 600 mm	<b>S-169</b> Préparez vous à descendre 450 x 600 mm
<b>S-170</b> École de ski 300 x 300 mm 450 x 450 mm	<b>S-171</b> Boutique de ski 300 x 300 mm 450 x 450 mm	<b>S-172</b> Restaurant 300 x 300 mm 450 x 450 mm	<b>S-180</b> Premiers soins 300 x 300 mm 450 x 450 mm	<b>S-190</b> Permission de planche à neige 450 x 450 mm	<b>S-191</b> Interdiction de planche à neige 450 x 450 mm
<b>S-192</b> Numéro de piste permise 450 x 600 mm	<b>S-240</b> Cédez le passage 600 x 600 x 600 mm	<b>S-241</b> Piste fermée 450 x 600 mm	<b>S-242</b> Descente rapide interdite 300 x 300 mm 450 x 450 mm	<b>S-243</b> Pas de ski ni bâton 200 x 200 mm 300 x 300 mm	<b>S-244</b> Ski de fond interdit 200 x 200 mm 300 x 300 mm
<b>S-245</b> Motoneiges interdites 200 x 200 mm 300 x 300 mm	<b>S-246</b> Raquettes interdites 200 x 200 mm 300 x 300 mm	<b>S-247</b> Piétons interdits 200 x 200 mm 300 x 300 mm	<b>S-248</b> Interdit de jeter des déchets 200 x 200 mm 300 x 300 mm	<b>S-249</b> Interdit aux animaux 300 x 300 mm	<b>S-250</b> Saut interdit 450 x 600 mm
<b>S-251</b> Véhicules tout-terrain interdits 300 x 300 mm 450 x 450 mm	<b>S-251</b> Sous-bois interdit 300 x 300 mm 450 x 450 mm	<b>S-270</b> Piste réser. entrain. ou compé. 450 x 450 mm	<b>S-271</b> Rétrécissement de la piste 450 x 450 mm	<b>S-272</b> Présence de canon à neige 450 x 450 mm	<b>S-273</b> Présence de surfaceuse 450 x 450 mm



S-274

Présence d'une borne

450 x 450 mm



S-275

Présence de roches

450 x 450 mm



S-276

Présence de canon à neige

450 x 450 mm



S-278

Présence de plaques de glace

450 x 450 mm



S-280

Piste pour experts seulement

450 x 450 mm



S-281

Endroit à découvert

450 x 450 mm



S-282

Condition min. ski non recomm.

450 x 450 mm



S-283

Pente raide

450 x 450 mm



S-400

Danger

230 mm de diamètre



S-401

Limite

230 mm de diamètre

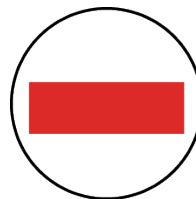

S-402

Interdiction d'entrer

230 mm de diamètre



S-403

Lentement

230 mm de diamètre



S-404

Fermé

230 mm de diamètre



S-405

Falaise

230 mm de diamètre



S-406

Attention

230 mm de diamètre

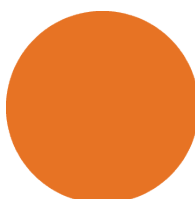

S-407

Selon vos besoins

230 mm de diamètre



S-450

Stationnement autorisé

300 x 300 mm

450 x 450 mm



S-451

Stationnement interdit

300 x 300 mm

450 x 450 mm



S-452

Défense d'entrer

300 x 300 mm

450 x 450 mm



S-453

Défense de stat. à cet endroit

300 x 450 mm



S-454

Sens unique

450 x 150 mm

750 x 250 mm



S-460

Les interdictions

750 x 600 mm





**S-500**  
Premiers soins  
300 x 300 mm  
450 x 450 mm



**S-501**  
Direction  
300 x 300 mm  
450 x 450 mm



**S-502**  
Direction  
300 x 300 mm  
450 x 450 mm



**S-503**  
Direction  
300 x 300 mm  
450 x 450 mm

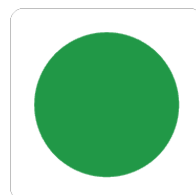

**S-504**  
Degré de difficulté : Facile  
300 x 300 mm  
450 x 450 mm



**S-505**  
Degré de difficulté : Moyen  
300 x 300 mm  
450 x 450 mm

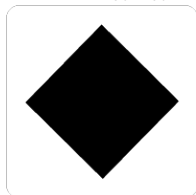

**S-506**  
Degré de difficulté : Difficile  
300 x 300 mm  
450 x 450 mm



**S-507**  
Sentier de randonnée  
300 x 300 mm  
450 x 450 mm



**S-508**  
Piste pour patin  
300 x 300 mm  
450 x 450 mm



**S-509**  
Aire de raquette  
300 x 300 mm  
450 x 450 mm



**S-510**  
Sentier de motoneige  
300 x 300 mm  
450 x 450 mm



**S-511**  
Nom de la piste  
320 x 160 mm



**S-512**  
Jonction  
300 x 300 mm  
450 x 450 mm



**S-513**  
Type de piste  
320 x 160 mm



**S-514**  
Type de piste  
320 x 160 mm



**S-515**  
Accueil  
300 x 300 mm  
450 x 450 mm



**S-516**  
Téléphone  
300 x 300 mm  
450 x 450 mm



**S-517**  
Stationnement  
300 x 300 mm  
450 x 450 mm



**S-518**  
Refuge  
300 x 300 mm  
450 x 450 mm



**S-519**  
Abri ou halte  
300 x 300 mm  
450 x 450 mm



**S-520**  
Camping  
300 x 300 mm  
450 x 450 mm



**S-521**  
Camping de groupe  
300 x 300 mm  
450 x 450 mm



**S-522**  
Restaurant  
300 x 300 mm  
450 x 450 mm



**S-523**  
Pique-nique  
300 x 300 mm  
450 x 450 mm



**S-524**  
Boutique  
300 x 300 mm  
450 x 450 mm



**S-525**  
Toilettes  
300 x 300 mm  
450 x 450 mm



**S-550**  
Arrêt obligatoire  
300 x 300 mm  
450 x 450 mm



**S-551**  
Cédez le passage  
600 x 600 x 600 mm



**S-552**  
Pas de patin obligatoire  
300 x 300 mm  
450 x 450 mm



**S-553**  
Entrée interdite  
300 x 300 mm  
450 x 450 mm



**S-554**  
Déf. de dépasser ou circ. côte-à-côte  
300 x 300 mm  
450 x 450 mm



**S-555**  
Pas de patin interdit  
300 x 300 mm  
450 x 450 mm



**S-556**  
Acc. interdit aux skieurs de fond  
300 x 300 mm  
450 x 450 mm



**S-557**  
Acc. interdit aux raquetteurs  
300 x 300 mm  
450 x 450 mm



**S-558**  
Accès interdit aux piétons  
300 x 300 mm  
450 x 450 mm



**S-559**  
Acc. interdit aux motoneiges  
300 x 300 mm  
450 x 450 mm



<b>S-560</b> <i>Acc. interdit aux quads</i> 300 x 300 mm 450 x 450 mm	<b>S-561</b> <i>Acc. interdit aux animaux dom.</i> 300 x 300 mm 450 x 450 mm	<b>S-562</b> <i>Défense de jeter des déchets</i> 300 x 300 mm 450 x 450 mm	<b>S-563</b> <i>Défense de faire du feu</i> 300 x 300 mm 450 x 450 mm	<b>S-564</b> <i>Défense de couper du bois</i> 300 x 300 mm 450 x 450 mm	<b>S-565</b> <i>Skis et bâtons interdits</i> 300 x 300 mm 450 x 450 mm
--	---	---	--	--	---



<b>S-566</b> <i>Stationnement interdit</i> 300 x 300 mm 450 x 450 mm	<b>S-600</b> <i>Pente raide</i> 300 x 300 mm 450 x 450 mm	<b>S-601</b> <i>Virage</i> 300 x 300 mm 450 x 450 mm	<b>S-602</b> <i>Virage</i> 300 x 300 mm 450 x 450 mm	<b>S-603</b> <i>Virage double</i> 300 x 300 mm 450 x 450 mm	<b>S-604</b> <i>Virage double</i> 300 x 300 mm 450 x 450 mm
---	--	---	---	--	--



<b>S-605</b> <i>Passage étroit</i> 300 x 300 mm 450 x 450 mm	<b>S-606</b> <i>Intersection</i> 300 x 300 mm 450 x 450 mm	<b>S-607</b> <i>Côte à côté de sent. ski et motoneige</i> 300 x 300 mm 450 x 450 mm	<b>S-608</b> <i>Côte à côté de sent. ski et motoneige</i> 300 x 300 mm 450 x 450 mm	<b>S-609</b> <i>Circulation dans les deux sens</i> 300 x 300 mm 450 x 450 mm	<b>S-610</b> <i>Sign. avancé d'arrêt oblig.</i> 300 x 300 mm 450 x 450 mm
---	---	--	--	---	--



<b>S-611</b> <i>Sign. avancé traverse d'auto</i> 300 x 300 mm 450 x 450 mm	<b>S-612</b> <i>Sign. avancé passage motoneiges</i> 300 x 300 mm 450 x 450 mm	<b>S-613</b> <i>Sign. avancé passage quads</i> 300 x 300 mm 450 x 450 mm	<b>S-614</b> <i>Sign. avancé traverse voie ferrée</i> 300 x 300 mm 450 x 450 mm	<b>S-615</b> <i>Sign. avancé traverse de skieurs</i> 300 x 300 mm 450 x 450 mm
---	--	---	--	---

# THE BEST WAY TO GET THE JOB DONE



<b>MP-2-P</b> Motoneige 300 x 200 mm	<b>MP-010</b> Arrêt 450 x 450 mm	<b>MP-020-1</b> Cédez le passage 450 x 450 x 450 mm	<b>MP-040</b> Entrée interdite 450 x 450 mm	<b>MP-040-P</b> Entrée interdite 300 x 150 mm	<b>MP-070-2</b> Limite de vitesse 300 x 375 mm
<b>MP-040-P</b> Secteur résidentiel 300 x 150 mm	<b>MP-080-1</b> Sens unique 450 x 150 mm	<b>MP-080-3</b> Circulation à double sens 300 x 375 mm	<b>MP-090-D</b> Contournement d'obstacle 300 x 375 mm	<b>MP-090-G</b> Contournement d'obstacle 300 x 375 mm	<b>MP-110-1</b> Obligation d'aller tout droit 450 x 450 mm
<b>MP-110-2-D</b> Obligation tourner à droite 450 x 450 mm	<b>MP-110-2-G</b> Obligation tourner à gauche 450 x 450 mm	<b>MP-110-3-G</b> Oblig. d'aller tout droit ou à gauche 450 x 450 mm	<b>MP-110-3-D</b> Oblig. d'aller tout droit ou à droite 450 x 450 mm	<b>MP-110-4</b> Oblig. tourner à droite ou à gauche 450 x 450 mm	<b>MP-110-5</b> Inter. de faire demi-tour 450 x 450 mm
<b>MP-110-6</b> Inter. de tourner à gauche 450 x 450 mm	<b>MP-110-7</b> Inter. de tourner à droite 450 x 450 mm	<b>MP-110-8</b> Inter. d'aller tout droit 450 x 450 mm	<b>MP-110-P-1</b> Heures et jours 300 x 150 mm	<b>MP-110-P-2</b> Heures et jours 300 x 230 mm	<b>MP-120-7</b> Trajet oblig. pour motoneiges 450 x 450 mm
<b>MP-120-15</b> Trajet oblig. pour motoneiges et V.L.T. 450 x 450 mm	<b>MP-120-17-D</b> Tjt oblig. séparé motoneiges et skieurs de fond 450 x 450 mm	<b>MP-120-17-G</b> Tjt oblig. séparé motoneiges et skieurs de fond 450 x 450 mm	<b>MP-120-18-D</b> Tjt oblig. séparé motoneiges et V.L.T. 450 x 450 mm	<b>MP-120-18-G</b> Tjt oblig. séparé motoneiges et V.L.T. 450 x 450 mm	<b>MP-120-19-D</b> Tjt oblig. séparé motoneiges et raquetteurs 450 x 450 mm
<b>MP-120-19-G</b> Tjt oblig. séparé motoneiges et raquetteurs 450 x 450 mm	<b>MP-120-20-D</b> Tjt oblig. séparé motoneiges et cavaliers 450 x 450 mm	<b>MP-120-10-G</b> Tjt oblig. séparé motoneiges et cavaliers 450 x 450 mm	<b>MP-120-21-D</b> Tjt oblig. séparé motoneiges et train. à chiens 450 x 450 mm	<b>MP-120-21-G</b> Tjt oblig. séparé motoneiges et train. à chiens 450 x 450 mm	<b>MP-120-22-D</b> Tjt oblig. séparé motoneiges et piétons 450 x 450 mm



**MP-120-22-G**  
*Tjt oblig. séparé motoneiges et piétons*  
450 x 450 mm



**MP-120-29**  
*Oblig. de circuler sur l'accotement*  
450 x 450 mm



**MP-120-30**  
*Oblig. de circuler sur l'accotement*  
450 x 450 mm



**MP-120-31**  
*Oblig. de circuler sur le trottoir*  
450 x 450 mm



**MP-120-P-2**  
*Oblig. de circuler sur l'accotement*  
300 x 150 mm



**MP-120-P-3**  
*Oblig. de circuler sur le trottoir*  
300 x 150 mm



**MP-130-4**  
*Accès interdit aux automobiles*  
450 x 450 mm



**MP-130-5**  
*Accès interdit aux motocyclistes*  
450 x 450 mm



**MP-130-6**  
*Accès interdit aux bicyclettes*  
450 x 450 mm



**MP-130-7**  
*Accès interdit aux quads*  
450 x 450 mm



**MP-130-8**  
*Accès interdit aux auto/moto*  
450 x 450 mm



**MP-130-11**  
*Accès interdit aux piétons/bicyclettes*  
450 x 450 mm



**MP-130-12**  
*Accès interdit aux piétons*  
450 x 450 mm



**MP-130-13**  
*Accès interdit aux cavaliers*  
450 x 450 mm



**MP-130-14**  
*Accès interdit aux motoneiges*  
450 x 450 mm



**MP-130-38**  
*Accès interdit aux motoneiges/quads*  
450 x 450 mm



**MP-130-39**  
*Accès interdit aux motoneiges/quads*  
450 x 450 mm



**MP-130-40**  
*Accès interdit aux auto/motoneiges*  
450 x 450 mm



**MP-130-41**  
*Accès interdit aux auto/quads*  
450 x 450 mm



**MP-130-42**  
*Accès interdit aux traîneaux à chiens*  
450 x 450 mm



**MP-130-43**  
*Accès interdit aux skieurs*  
450 x 450 mm



**MP-130-44**  
*Accès interdit aux cavaliers/train. à chiens*  
450 x 450 mm



**MP-130-45**  
*Accès interdit aux raquetteurs/skieurs*  
450 x 450 mm



**MP-130-46**  
*Accès interdit aux piétons/skieurs*  
450 x 450 mm



**MP-130-62**  
*Accès interdit aux motocyclistes*  
450 x 450 mm



**MP-140-3**  
*Interdiction de dépasser*  
450 x 450 mm



**MP-150-2**  
*Stationnement réglementé*  
300 x 450 mm



**MP-150-2-D**  
*Stationnement réglementé*  
300 x 450 mm



**MP-150-2-G**  
*Stationnement réglementé*  
300 x 450 mm



**MP-150-2-G-D**  
*Stationnement réglementé*  
300 x 450 mm



**MP-150-7**  
*Stationnement réglementé*  
300 x 450 mm



**MP-150-7-D**  
*Stationnement réglementé*  
300 x 450 mm



**MP-150-7-G**  
*Stationnement réglementé*  
300 x 450 mm



**MP-150-7-G-D**  
*Stationnement réglementé*  
300 x 450 mm



**MP-160-1**  
*Arrêt interdit*  
300 x 450 mm



**MP-160-1-D**  
*Arrêt interdit*  
300 x 450 mm



**MP-160-1-G**

Arrêt interdit

300 x 450 mm



**MP-160-1-G-D**

Arrêt interdit

300 x 450 mm

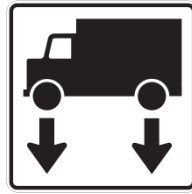

**MP-210**

Dégel

300 x 300 mm



**MP-230-P**

Fin

300 x 150 mm



**MP-240-P-1**

Direction

300 x 150 mm



**MP-240-P-2-D**

Direction

300 x 150 mm



**MP-240-P-2-G**

Direction

300 x 150 mm



**MP-240-P-3**

Direction

300 x 150 mm



**MP-240-P-3-G-D**

Direction

300 x 150 mm



**MP-240-P-4-D**

Direction

300 x 150 mm



**MP-240-P-4-G**

Direction

300 x 150 mm



**MP-240-P-5-D**

Direction

300 x 150 mm



**MP-240-P-5-G**

Direction

300 x 150 mm



**MP-240-P-9-D**

Direction

300 x 150 mm



**MP-240-P-9-G**

Direction

300 x 150 mm



**MP-270-2-D**

Passage pour piétons

300 x 375 mm



**MP-310**

Défense de jeter des ordures

300 x 300 mm



**MD-2-P**

Motoneige

300 x 200 mm



**MD-010-1**

Signal avancé d'arrêt

300 x 300 mm



**MD-050-1**

Signal avancé feux de circulation

300 x 300 mm



**MD-070**

Signal avancé limite de vitesse

300 x 300 mm



**MD-080-1**

Signal avancé circ. double sens

300 x 300 mm



**MD-090-1**

Début sentier séparé

300 x 300 mm



**MD-090-2**

Fin sentier séparé

300 x 300 mm



**MD-110-1-D**

Virage à droite

300 x 300 mm



**MD-110-1-G**

Virage à gauche

300 x 300 mm



**MD-110-2-D**

Virage à droite

300 x 300 mm



**MD-110-2-G**

Virage à gauche

300 x 300 mm



**MD-110-3-D**

Virage double

300 x 300 mm



**MD-110-3-G**

Virage double

300 x 300 mm



**MD-110-4-D**

Virage double

300 x 300 mm



**MD-110-4-G**

Virage double

300 x 300 mm



**MD-110-5-D**

Virage triple

300 x 300 mm



**MD-110-5-G**

Virage triple

300 x 300 mm



**MD-110-6-D**

Virage à droite, 180°

300 x 300 mm



**MD-110-6-G**

Virage à gauche, 180°

300 x 300 mm



**MD-110-P-2**

Vitesse recommandée

300 x 300 mm



**MD-130-1**

Flèche directionnelle

300 x 300 mm



**MD-130-2**

Flèche directionnelle

300 x 300 mm



**MD-160-D**

Intersection en T dans une courbe

300 x 300 mm



**MD-160-G**

Intersection en T dans une courbe

300 x 300 mm



**MD-170-1**

Intersection en croix

300 x 300 mm



**MD-170-2**

Intersection en T

300 x 300 mm



**MD-170-3**

Intersection

300 x 300 mm



**MD-170-4-D**

Intersection en Y, à droite

300 x 300 mm



**MD-170-4-G**

Intersection en Y, à gauche

300 x 300 mm



**MD-175**

Signal avancé passage routier

300 x 300 mm



**MD-180-1**

Signal avancé passage à niveau

300 x 300 mm

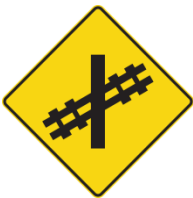

**MD-180-2**

Signal avancé passage à niveau

300 x 300 mm



**MD-180-3**

Signal avancé passage à niveau

300 x 300 mm



**MD-180-4**

Signal avancé passage à niveau

300 x 300 mm



**MD-180-5**

Signal avancé passage à niveau

300 x 300 mm



**MD-180-6-D**

Signal avancé passage à niveau

300 x 300 mm



**MD-180-6-G**

Signal avancé passage à niveau

300 x 300 mm



**MD-200**

Passage étroit

300 x 300 mm



**MD-200-P-2**

Passage 1 voie

300 x 150 mm



**MD-210-1**

Sentier rétréci

300 x 300 mm



**MD-230-9**

Pente raide

300 x 300 mm



**MD-230-10**

Pente raide

300 x 300 mm



**MD-240-3**

Visibilité restreinte

300 x 300 mm



**MD-240-P-10-D**

Emplacement

300 x 150 mm



**MD-240-P-10-G**

Emplacement

300 x 150 mm



**MD-245-P-1**

Distance

300 x 150 mm



**MD-245-P-2**

Distance

300 x 150 mm



**MD-270-2-D**

Signal avancé passage piétons

300 x 300 mm



**MD-270-9**

Passage de motoneiges

300 x 300 mm



**MD-270-12**

Passage de cavaliers

300 x 300 mm



**MD-270-13**

Présence possible de chevreuils

300 x 300 mm



**MD-270-14**

Présence possible d'orignaux

300 x 300 mm



**MD-270-15**

Présence possible de caribous

300 x 300 mm



**MD-270-21**

Passage pour skieurs

300 x 300 mm



**MD-270-22**

Passage pour raquetteurs

300 x 300 mm



MD-270-23

Passage pour traîneaux à chiens  
300 x 300 mm



MD-280

Fin d'un sentier  
300 x 300 mm



MD-290-D

Balise de danger à droite  
200 x 600 mm



MD-290-G

Balise de danger à gauche  
200 x 600 mm



MD-301-1

Chevron d'alignement  
300 x 375 mm



MD-310-5

Sentier glissant  
300 x 300 mm



MD-360

Sentier cahoteux  
300 x 300 mm



MD-365

Trou  
300 x 300 mm



MD-430-2

Signal avancé chaussée désignée  
300 x 300 mm



MD-430-4

Signal avancé sentier désigné  
300 x 300 mm



MD-430-6

Signal avancé chaussée désignée  
300 x 300 mm



MD-440-2

Chaussée désignée, auto/motoneiges  
300 x 300 mm



MD-440-4

Sentier désigné, motoneiges/quads  
300 x 300 mm



MD-440-6

Chaussée désignée, grumiers/motoneiges  
300 x 300 mm



MD-510

Étendue d'eau gelée  
300 x 300 mm



MD-520

Plantation d'arbres  
300 x 300 mm



MD-530

Surfaceuse sur le sentier  
300 x 300 mm



MT-050-1

Présence de travailleurs  
300 x 300 mm



MT-080-9

Sentier barré  
300 x 300 mm



MT-090-1

Détour  
300 x 300 mm



MT-090-1

Détour  
300 x 300 mm



MT-090-1

Détour  
300 x 300 mm



MT-090-1

Détour  
300 x 300 mm



MT-090-1

Détour  
300 x 300 mm



MT-245-P-2

Distance  
300 x 150 mm



MT-250-P-2

Étendue  
300 x 150 mm



MT-250-P-3

Étendue  
300 x 150 mm



MI-100-1

Dir. de mun. 1 dest. et distance  
900 x 150 mm



MI-100-2

Dir. de mun. 2 dest. et distance  
900 x 300 mm



MI-100-1

Dir. de mun. 3 dest. et distance  
900 x 450 mm



MI-110-1

Rappel distance de mun.  
600 x 150 mm



MI-110-2

Rappel distance de 2 mun.  
600 x 300 mm



MI-121-1

Id. d'un sentier régional  
300 x 300 mm



MI-131-1

Id. d'un sentier Trans-Québec  
300 x 300 mm



MI-150-4

Entrée d'agglomération  
900 x 150 mm



MI-150-6

Limite terr. club de motoneigistes  
900 x 150 mm





MI-200-P-1-BL

MI-200-P-1-V

MI-200-P-2-BL

MI-200-P-2-V

MI-200-P-3-BL

MI-200-P-3-V

Point cardinal

Point cardinal

Point cardinal

Point cardinal

Point cardinal

Point cardinal

300 x 150 mm

300 x 150 mm

300 x 150 mm

300 x 150 mm

300 x 150 mm

300 x 150 mm



MI-200-P-4-BL

MI-200-P-4-V

MI-210-1

MI-210-2

MI-210-3

MI-210-4

Point cardinal

Point cardinal

Élément hydrographique

Élément hydrographique

Élément hydrographique

Élément hydrographique

300 x 150 mm

300 x 150 mm

900 x 150 mm

900 x 150 mm

900 x 150 mm

900 x 150 mm

Chute BLANCHE

Mont ROUEMONT



MI-210-5

MI-220

MI-225-P-BL

MI-225-P-V

MI-230-P-BL

MI-230-P-V

Élément hydrographique

Élément hydrographique

Début

Début

Fin

Fin

900 x 150 mm

900 x 150 mm

300 x 150 mm

300 x 150 mm

300 x 150 mm

300 x 150 mm



MI-235-P-BL

MI-235-P-V

MI-240-P-1-BL

MI-240-P-1-V

MI-240-P-2-D-BL

MI-240-P-2-D-V

Jonction

Jonction

Direction

Direction

Direction

Direction

300 x 150 mm

300 x 150 mm

300 x 150 mm

300 x 150 mm

300 x 150 mm

300 x 150 mm



MI-240-P-2-G-BL

MI-240-P-2-G-V

MI-240-P-3-BL

MI-240-P-3-V

MI-240-P-3-G-D-BL

MI-240-P-3-G-D-V

Direction

Direction

Direction

Direction

Direction

Direction

300 x 150 mm

300 x 150 mm

300 x 150 mm

300 x 150 mm

300 x 150 mm

300 x 150 mm



MI-240-P-4-D-BL

MI-240-P-4-D-V

MI-240-P-4-G-BL

MI-240-P-4-G-V

MI-240-P-5-D-BL

MI-240-P-5-D-V

Direction

Direction

Direction

Direction

Direction

Direction

300 x 150 mm

300 x 150 mm

300 x 150 mm

300 x 150 mm

300 x 150 mm

300 x 150 mm



MI-240-P-5-G-BL

MI-240-P-5-G-V

MI-240-P-6-BL

MI-240-P-6-V

MI-240-P-7-D-BL

MI-240-P-7-D-V

Direction

Direction

Direction et distance

Direction et distance

Direction et distance

Direction et distance

300 x 150 mm

300 x 150 mm

300 x 150 mm

300 x 150 mm

300 x 150 mm

300 x 150 mm



MI-240-P-7-G-BL

MI-240-P-7-G-V

MI-240-P-8-D-BL

MI-240-P-8-D-V

MI-240-P-8-G-BL

MI-240-P-8-G-V

Direction

Direction et distance

Direction et distance

Direction et distance

Direction et distance

Direction et distance

300 x 150 mm

300 x 150 mm

300 x 150 mm

300 x 150 mm

300 x 150 mm

300 x 150 mm



MI-240-P-9-D-BL

MI-240-P-9-D-V

MI-240-P-9-G-BL

MI-240-P-9-G-V

MI-280-1

MI-280-2

Direction

Direction

Direction

Direction

Hôpital

CLSC

300 x 150 mm

300 x 150 mm

300 x 150 mm

300 x 150 mm

300 x 300 mm

300 x 300 mm



MI-350-9

MI-350-10

MI-375-1

MI-375-2

MI-376-1

MI-450-D

Aire de stat. pour motoneigistes

Aire de stationnement connexe

Cul-de-sac

Présignalisation de Cul-de-sac

Période d'ouverture

Belvédère à droite

300 x 300 mm

300 x 300 mm

300 x 150 mm

300 x 150 mm

300 x 300 mm

300 x 300 mm



MI-450-G

MI-520-5

MI-530-3

MI-600-1

MI-600-2

MI-610-3

Belvédère à gauche

Centre infotouriste

Achem. déquip. touristiques privés

Services publics, abri

Services publics, abri chauffé

Sign. des services commerciaux

300 x 300 mm

300 x 300 mm

900 x 200 mm

300 x 300 mm

300 x 300 mm

900 x 200 mm



MI-610-4

MI-610-5

Sign. des services commerciaux

Sign. des services commerciaux

900 x 200 mm

900 x 200 mm



# WATER

# RÉGLEMENTATION



CASQUE  
PROTECTEUR  
OBLIGATOIRE

**C0-1**  
*Casque protecteur oblig.*  
300 x 450 mm



LUNETTES  
PROTECTRICES  
OBLIGATOIRES

**C0-2**  
*Lunettes protectrices oblig.*  
300 x 450 mm



PROTECTEUR  
AURICULAIRE  
OBLIGATOIRE

**C0-3**  
*Protecteur auriculaire oblig.*  
300 x 450 mm



MASQUE  
RESPIRATOIRE  
OBLIGATOIRE

**C0-4**  
*Masque respiratoire oblig.*  
300 x 450 mm



GANTS  
PROTECTEURS  
OBLIGATOIRES

**C0-5**  
*Gants protecteurs oblig.*  
300 x 450 mm



SIGNELEZ  
TOUTES  
BLESSURES

**C0-6**  
*Signalez toutes blessures*  
300 x 450 mm



CHAUSSURES  
PROTECTRICES  
OBLIGATOIRES

**C0-7**  
*Chaussures protectrices oblig.*  
300 x 450 mm



JETEZ  
LES  
DÉCHETS

**C0-8**  
*Jetez les déchets*  
300 x 450 mm



PASSAGE  
POUR  
PIÉTONS

**C0-9**  
*Passage piétons*  
300 x 450 mm



FILET  
À CHEVEUX  
OBLIGATOIRE

**C0-10**  
*Filet à cheveux oblig.*  
300 x 450 mm



PORT DE LA  
CEINTURE DE  
SÉCURITÉ  
OBLIGATOIRE

**C0-11**  
*Port de ceinture oblig.*  
300 x 450 mm



TENEZ  
CETTE PORTE  
FERMÉE

**C0-12**  
*Tenez cette porte fermée*  
300 x 450 mm



GARDEZ  
CE POSTE  
DE TRAVAIL  
PROPRE

**C0-13**  
*Gardez ce poste de travail propre*  
300 x 450 mm



ÉQUIPEMENT  
DE  
PROTECTION  
OBLIGATOIRE

**C0-14**  
*Équipement de protection oblig.*  
300 x 450 mm



SIGNELEZ  
TOUTES  
CONDITIONS  
DANGEREUSES

**C0-15**  
*Sign. toutes conditions dangereuses*  
300 x 450 mm

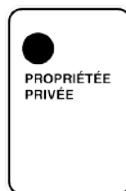

PROPRIÉTÉ  
PRIVÉE

**C0-16**  
*Propriété privée*  
300 x 450 mm



RESPIRATEUR  
À CARTOUCHES  
OBLIGATOIRES

**C0-17**  
*Respirateur à cartouches oblig.*  
300 x 450 mm



RESPIRATEUR  
OBLIGATOIRE

**C0-18**  
*Respirateur oblig.*  
300 x 450 mm



VISIÈRE  
DE SÉCURITÉ  
OBLIGATOIRE

**C0-19**  
*Visière de sécurité oblig.*  
300 x 450 mm



SARRAU  
OBLIGATOIRE

**C0-20**  
*Sarrau oblig.*  
300 x 450 mm



MÉTAL  
SEULEMENT

**C0-21**  
*Métal seulement*  
300 x 450 mm



PAPIER  
SEULEMENT

**C0-22**  
*Papier seulement*  
300 x 450 mm



CHIFFONS SALES  
SEULEMENT

**C0-23**  
*Chiffons sales seulement*  
300 x 450 mm



GARDEZ  
VERROUILLÉ

**C0-24**  
*Gardez verrouillé*  
300 x 450 mm



ATTACHEZ LES  
BOUTEILLES  
DE GAZ

**C0-25**  
*Attachez les bouteilles de gaz*  
300 x 450 mm



VOTRE  
MESSAGE

**C0-100**  
*Votre message*  
300 x 450 mm

# INFORMATION - URGENCE SANTÉ ET GÉNÉRALE



PREMIERS SOINS



CIVIÈRE



TÉLÉPHONE D'URGENCE



SORTIE D'URGENCE



INTERRUPTEUR D'URGENCE



BOUCHE D'INCENDIE

**CU-1** Premiers soins 300 x 450 mm    **CU-2** Civière 300 x 450 mm    **CU-3** Téléphone d'urgence 300 x 450 mm    **CU-4** Sortie d'urgence 300 x 450 mm    **CU-5** Interrupteur d'urgence 300 x 450 mm    **CU-6** Bouche d'incendie 300 x 450 mm



LANCE D'INCENDIE



SIGNAL D'INCENDIE



HACHE D'INCENDIE



POSTE D'EXTINCTEUR



DOUCHE D'URGENCE



DOUCHE OCULAIRE

**CU-7** Lance d'incendie 300 x 450 mm    **CU-8** Signal d'incendie 300 x 450 mm    **CU-9** Hache d'incendie 300 x 450 mm    **CU-10** Poste d'extincteur 300 x 450 mm    **CU-11** Douche d'urgence 300 x 450 mm    **CU-12** Douche oculaire 300 x 450 mm



SOUPAPE DE GICLÉUR

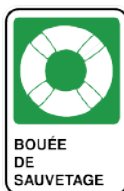

BOUÉE DE SAUVETAGE

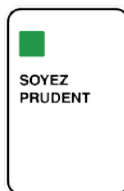

SOYEZ PRUDENT



NE PARLEZ PAS À L'OPÉRATEUR DE CETTE MACHINE



VOTRE MESSAGE

**CU-13** Soupape de gicleur 300 x 450 mm    **CU-14** Bouée de sauvetage 300 x 450 mm    **CU-15** Soyez prudent 300 x 450 mm    **CU-16** Ne parlez pas à l'opérateur... 300 x 450 mm    **CU-100** Votre message 300 x 450 mm



TOILETTES



HOMMES



FEMMES



SERVICE POUR HANDICAPÉ



SORTIE



INFORMATIONS

**CG-1** Toilettes 300 x 450 mm    **CG-2** Hommes 300 x 450 mm    **CG-3** Femmes 300 x 450 mm    **CG-4** Service pour handicapé 300 x 450 mm    **CG-5** Sortie 300 x 450 mm    **CG-6** Informations 300 x 450 mm



DOUCHES



FUMEURS



RESTAURANT



CASSE-CROUTE



CONTENANT À DÉCHETS



DISTRIBUTEUR

**CG-7** Douches 300 x 450 mm    **CG-8** Fumeurs 300 x 450 mm    **CG-9** Restaurant 300 x 450 mm    **CG-10** Casse-croute 300 x 450 mm    **CG-11** Contenant à déchets 300 x 450 mm    **CG-12** Distributeur 300 x 450 mm



ESCALIER



TÉLÉPHONE



EAU POTABLE



ASSOCIATION DES TRAVAILLEURS



EMPLOYÉS SEULEMENT



VOTRE MESSAGE

**CG-13** Escalier 300 x 450 mm    **CG-14** Téléphone 300 x 450 mm    **CG-15** Eau potable 300 x 450 mm    **CG-16** Ass. des travailleurs 300 x 450 mm    **CG-17** Employés seulement 300 x 450 mm    **CG-100** Votre message 300 x 450 mm

# INFORMATION - EXPLOITATION / AVERTISSEMENT - DANGER



<b>CE-1</b> <i>Soupepe de commande</i> 300 x 450 mm	<b>CE-2</b> <i>Monte charge</i> 300 x 450 mm	<b>CE-3</b> <i>Ascenseur</i> 300 x 450 mm	<b>CE-4</b> <i>Tuyau d'air</i> 300 x 450 mm	<b>CE-5</b> <i>Interrupteur de commande</i> 300 x 450 mm	<b>CE-6</b> <i>Intercom</i> 300 x 450 mm
---	--	---	---	--	--



<b>CE-7</b> <i>Signal d'alarme</i> 300 x 450 mm	<b>CE-8</b> <i>Carburant</i> 300 x 450 mm	<b>CE-9</b> <i>tuyau d'évacuation</i> 300 x 450 mm	<b>CE-100</b> <i>Votre message</i> 300 x 450 mm
---	---	--	---



<b>CD-1</b> <i>Danger haute tension</i> 300 x 450 mm	<b>CD-2</b> <i>Danger engrenage</i> 300 x 450 mm	<b>CD-3</b> <i>Danger surface chaude</i> 300 x 450 mm	<b>CD-4</b> <i>Danger matière corrosive</i> 300 x 450 mm	<b>CD-5</b> <i>Danger gaz comprimé</i> 300 x 450 mm	<b>CD-6</b> <i>Danger poison</i> 300 x 450 mm
--	--	---	--	---	---



<b>CD-7</b> <i>Danger gaz toxique</i> 300 x 450 mm	<b>CD-8</b> <i>Danger matière inflammable</i> 300 x 450 mm	<b>CD-9</b> <i>Danger matière explosive</i> 300 x 450 mm	<b>CD-10</b> <i>Danger matière radioactive</i> 300 x 450 mm	<b>CD-11</b> <i>Danger arrêtez le moteur...</i> 300 x 450 mm	<b>CD-12</b> <i>Danger restez à l'écart</i> 300 x 450 mm
--	--	--	---	--	--



<b>CD-13</b> <i>Danger démarrage auto.</i> 300 x 450 mm	<b>CD-14</b> <i>Danger de coupures</i> 300 x 450 mm	<b>CD-15</b> <i>Danger d'éclaboussement</i> 300 x 450 mm	<b>CD-16</b> <i>Danger produits chimiques</i> 300 x 450 mm	<b>CD-17</b> <i>Danger trou ouvert</i> 300 x 450 mm	<b>CD-18</b> <i>Danger accès interdit</i> 300 x 450 mm
---	---	--	--	---	--



<b>CD-19</b> <i>Danger chute de glace</i> 300 x 450 mm	<b>CD-20</b> <i>Biohazard</i> 300 x 450 mm	<b>CD-100</b> <i>Danger votre message</i> 300 x 450 mm
--	--	--

# AVERTISSEMENT - ATTENTION / INTERDICTION



**CA-1**  
*Attention camions forestiers*  
300 x 450 mm



**CA-2**  
*Attention plancher glissant*  
300 x 450 mm



**CA-3**  
*Attention escalier*  
300 x 450 mm



**CA-4**  
*Attention à la marche*  
300 x 450 mm



**CA-5**  
*Attention aux boyaux*  
300 x 450 mm



**CA-6**  
*Attention grue mobile*  
300 x 450 mm



**CA-7**  
*Attention aux véhicules*  
300 x 450 mm



**CA-8**  
*Attention hommes au travail*  
300 x 450 mm



**CA-9**  
*Attention traverse de piétons*  
300 x 450 mm



**CA-10**  
*Attention au convoyeur*  
300 x 450 mm



**CA-11**  
*Attention homme au travail...*  
300 x 450 mm



**CA-12**  
*Attention homme au travail...*  
300 x 450 mm



**CA-13**  
*Attention démarrage auto.*  
300 x 450 mm



**CA-14**  
*Attention à votre tête*  
300 x 450 mm



**CA-100**  
*Votre message*  
300 x 450 mm



**CI-1**  
*Défense de fumer*  
300 x 450 mm



**CI-2**  
*Interdit de jeter des déchets*  
300 x 450 mm



**CI-3**  
*Eau non potable*  
300 x 450 mm



**CI-4**  
*Feu de camp interdit*  
300 x 450 mm



**CI-5**  
*Défense de manger*  
300 x 450 mm



**CI-6**  
*Chasse interdite*  
300 x 450 mm



**CI-7**  
*Défense d'ouvrir la valve*  
300 x 450 mm



**CI-8**  
*Flamme vive interdite*  
300 x 450 mm



**CI-9**  
*Ne pas toucher*  
300 x 450 mm



**CI-10**  
*Défense d'entrer*  
300 x 450 mm



**CI-11**  
*Personnel autorisé seulement*  
300 x 450 mm



**CI-12**  
*Défense de courir*  
300 x 450 mm



**CI-13**  
*Pas d'animaux*  
300 x 450 mm



**CI-14**  
*Accès interdit*  
300 x 450 mm



**CI-15**  
*Propriété privée*  
300 x 450 mm



**CI-16**  
*Pas d'admission sans affaire*  
300 x 450 mm



**CI-17**  
*Interdit aux personnes*  
300 x 450 mm



**CI-18**  
*Interdit aux automobiles*  
300 x 450 mm

# PANNEAUX DE PROTECTIONS OBLIGATOIRES

## *Personnalisés*

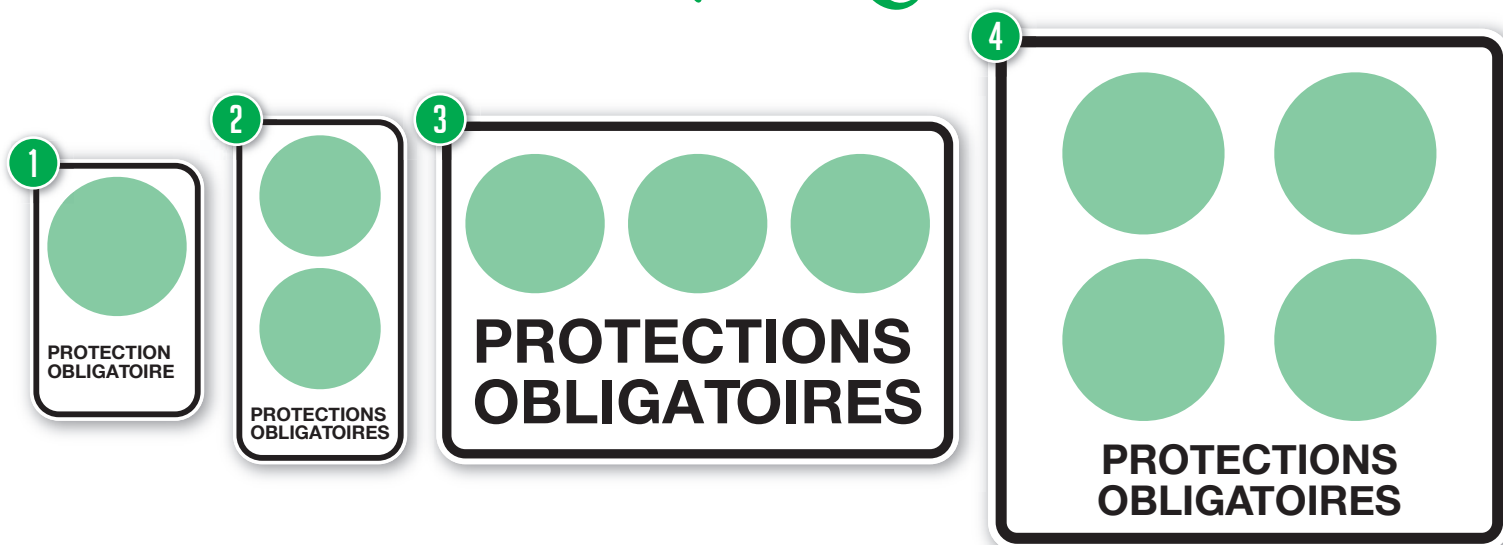

DIMENSIONS	1	2	3	4
	300 x 450 mm	300 x 600 mm	450 x 600 mm	600 x 600 mm
	450 x 600 mm	450 x 900 mm	600 x 900 mm	900 x 900 mm



CASQUE PROTECTEUR OBLIGATOIRE



LUNETTES PROTECTRICES OBLIGATOIRES



PROTECTEUR AURICULAIRE OBLIGATOIRE



GANTS PROTECTEURS OBLIGATOIRES



CHAUSSURES PROTECTRICES OBLIGATOIRES



DOSSARD OBLIGATOIRE



MASQUE RESPIRATOIRE OBLIGATOIRE



RESPIRATEUR À CARTOUCHES OBLIGATOIRE



RESPIRATEUR OBLIGATOIRE



VISIÈRE DE SÉCURITÉ OBLIGATOIRE



SARRAU OBLIGATOIRE

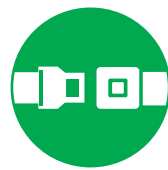

CEINTURE DE SÉCURITÉ OBLIGATOIRE



FILET À CHEVEUX OBLIGATOIRE



# TRANSPO



# TRANSPORT DE MARCHANDISES DANGEREUSES

## CLASSE 1

- Explosifs



P-10



P-11



P-12



P-13



P-14



P-15



P-16



P-10-1.1D

## CLASSE 2

- Gaz comprimés



P-20



P-22



P-24



P-26



P-28

## CLASSE 3

- Liquides inflammables



P-30

## CLASSE 4

- Solides inflammables;  
- Matières sujettes à l'inflammation spontanée;  
- Matières qui, au contact de l'eau, dégagent des gaz inflammables.



P-40



P-42



P-44

## CLASSE 5

- Matières comburantes;  
- Peroxydes organiques.



P-50



P-54

## CLASSE 6

- Matières toxiques;  
- Matières infectieuses.



P-60



P-62



P-64

## CLASSE 7

- Matières radioactives



P-70



P-72



P-74

## CLASSE 8

- Matières corrosives



P-80

## CLASSE 9

- Marchandises dangereuses diverses



P-90



P-200

- Exigence pour chargement mixte



**MT-100**

Largeur excessive - Avec ou sans pentures

2400 x 300 mm



**MT-103**

Triangle pour véhicule lent

350 x 400 mm

## PANNEAU D'AFFICHAGE COMPACT



Incluant  
\* Impression réfléchissante grade prismatique recto-verso  
\* Base de 9 livres  
(Livraison en sus)



9 lbs.

Panneau vertical de conception compacte  
44.5" H x 14.75" L

Impression personnalisée  
36" H x 8" L

Double face

Poignée surdimensionnée avec prise confortable

Facile à ramasser avec la base attachée

Conçu pour résister aux impacts répétés

Paroi latérale offrant résistance et durabilité

Base en caoutchouc recyclé de 9 livres

Empilable avec ou sans base

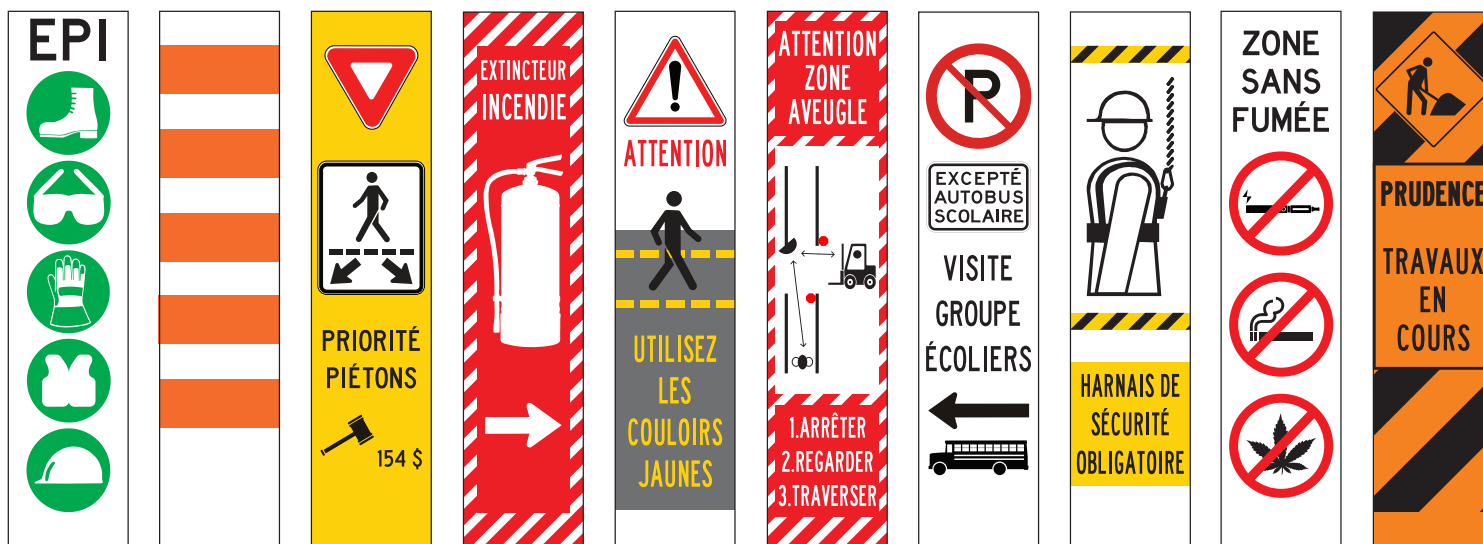



# signa**zip**

821, avenue de l'industrie  
Parc industriel, Amos, Québec  
J9T 4L6

819-727-9818  
866-666-9818 (Sans frais)

[ziplignes@cableamos.com](mailto:ziplignes@cableamos.com)

[signazip.com](http://signazip.com)